



1321 Millersport Hwy., Ste. 101
Amherst · New York 14221

P. 716.691.0900
F. 716.691.4773

West Herr Toyota Body Shop Addition
8129 Main Street
Clarence, NY

Addendum 1
December 13, 2018
Page 1 of 1

This Addendum is issued by the Architect and shall become part of the Contract Documents and is also subject to the terms and conditions set forth in Divisions 0 and 1.

Refer to the Project Manual:

- Item No. 1: Refer to the Instructions To Bidders, Paragraph 1; CHANGE December 18, 2018 to December 20, 2018.
- Item No. 2: DELETE the Bid Form and REPLACE with the attached Bid Form, Addendum 1. The Owner wishes the contractors to include a cost for the plumbing construction. While there are no plumbing drawings, the intent is for the plumbing to be design-build and a cost for the plumbing construction included with the General Construction.
- Item No 3: Attached is the Geotechnical Report, 3 pages (test borings and logs only). Insert in proper sequencing in the Project Manual.

Refer to the Drawings:

- Item No. 4: DELETE Drawings C102 and C104 dated 11/26/18 and REPLACE with attached Drawing C102, 12/10/18. The trench drain profile as well as the grease trap and sediment trap/catch basin has been modified. For clarification, attached are catalog cuts for the grease trap and riser.
- Item No. 5: Refer to Drawings S101 and Detail 3/S202; CLARIFICATION; the garage bay area slab thickness is 5" and all other areas are 4".

End of Addendum

WEST HERR TOYOTA BODY SHOP

BID FORM

ALL BIDDERS NOTE : Three signed copies of this bid form must be submitted.

TO: West Herr
3552 Southwestern Blvd.
Orchard Park, NY 14127
Attn: John Wabick

Pursuant to and in compliance with the Advertisement for Bids and/or the Instructions to Bidders, relating hereto, the undersigned hereby offers to furnish all plant, labor, materials, supplies, equipment and other facilities and things necessary and proper for, or incidental to, the Work as required by the plans and specifications as prepared by SILVESTRI ARCHITECTS, P.C., and all the following addenda issued by the Architect and mailed to the Undersigned prior to the opening of bids.

The bidder hereby acknowledges receipt of the following addenda:

Addendum No. _____ Dated _____

Addendum No. _____ Dated _____

Addendum No. _____ Dated _____

Base bid

(\$ _____)

Bid Breakdown:

General Construction:

Exterior Windows & Doors: \$ _____

Plumbing: \$ _____

Site Work: \$ _____

All Other Work: \$ _____

HVAC: Design/ Build by Owner Selected Contractor.

Electrical: Design/ Build by Owner Selected Contractor

General Contractor to provide percentage markup of Overhead, and Profit for any change orders to the project.

WEST HERR TOYOTA BODY SHOP

BID FORM

General Contractor Overhead Percent: _____ %

General Contractor Profit Percent: _____ %

Contractor Firm Name

The Undersigned agrees that upon request of the Owner, the amounts listed above will be broken down into separate prices, as requested by the Architect.

By submission of this bid, each Bidder and each person signing on behalf of any Bidder, and in the case of a joint bid each party thereto certifies as to its own organization, under penalty of perjury, that to the best of his knowledge and belief:

- (1) The prices in this Bid have been arrived at independently without collusion, consultation, communication or agreement, for the purpose of restricting competition, as to any matter relating to such prices with any other Bidder or with a competitor;
- (2) Unless otherwise required by law, the prices which have been quoted in this Bid have not been knowingly disclosed by the Bidder, and will not be knowingly disclosed by the Bidder prior to opening, directly or indirectly, to any other Bidder or to any competitor.
- (3) No attempt has been made or will be made by the Bidder to induce any person, partnership or corporation to submit or not to submit a Bid for the purpose of restricting competition.

This bid may be withdrawn at any time prior to the scheduled time for the opening of bids or any authorized postponement thereof.

FIRM

BY

TITLE

ADDRESS

_____ Corporation Seal if Applicable

*Here insert Bidder's Name. If a corporation, give the State of Incorporation using the phrase, "A corporation organized under the laws of the State of _____".

If the partnership, give names of partners, using also the phrase, "Co-partners trading and doing business under the firm name and style of _____".

If an individual, give the individual's name, using also the phrase "An individual doing business under the firm name and style of _____".

WEST HERR TOYOTA BODY SHOP

BID FORM

SUBSTITUTIONS:

The following spaces have been allotted for manufacturer's products that are considered equal to the material specified and the Addition or Deduction from the Base Bid.

NOTE: Base Bid will contain cost of items, written on the specifications, the substitution items and price quotations listed below may or may not be accepted by the Owner.

ITEM	MANUFACTURER	ADD/DEDUCT
1. _____	_____	\$
2. _____	_____	\$
3. _____	_____	\$
4. _____	_____	\$
5. _____	_____	\$
6. _____	_____	\$
7. _____	_____	\$
8. _____	_____	\$
9. _____	_____	\$
10. _____	_____	\$

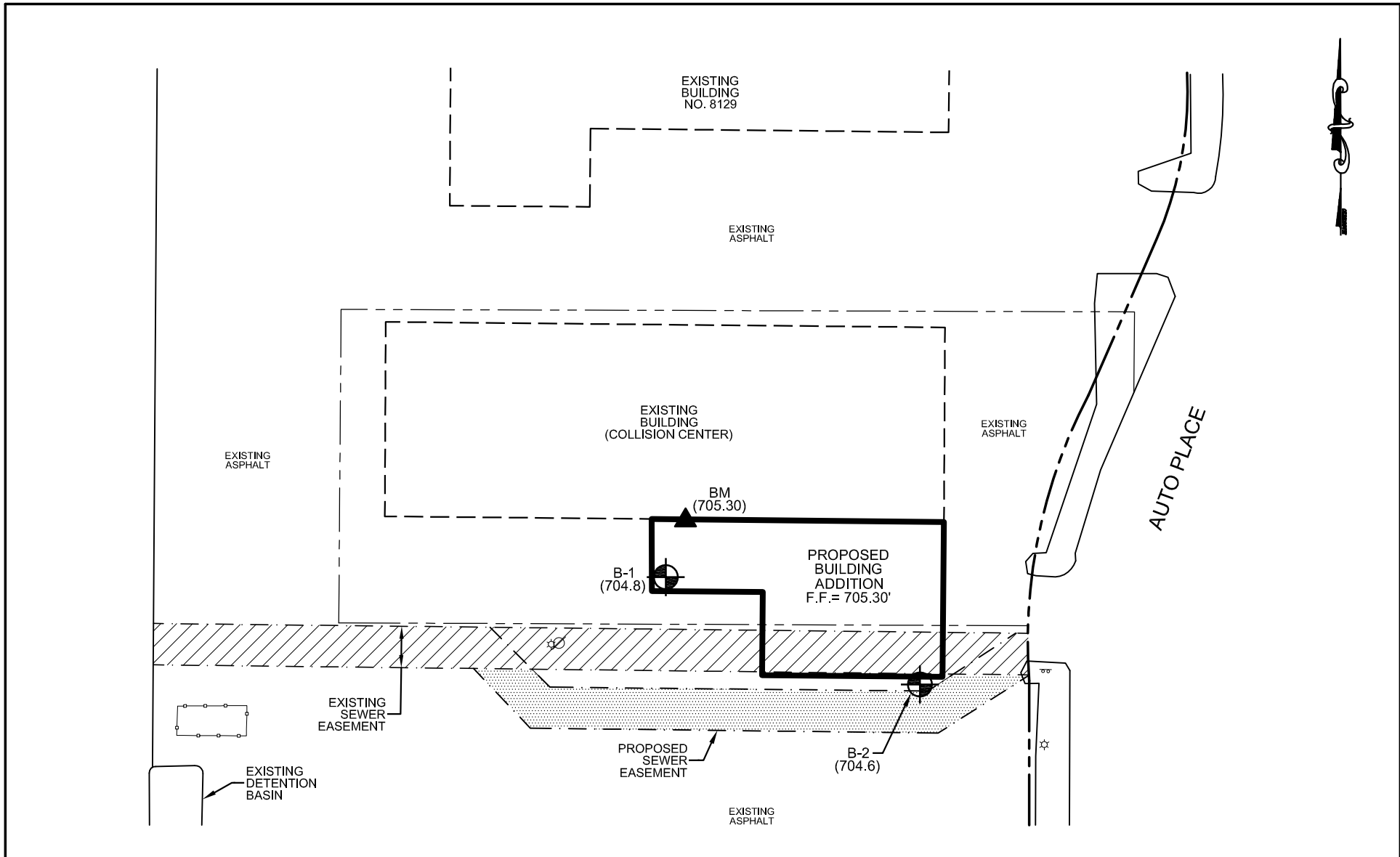

LEGEND	
	B-2 = TEST BORING & NO.
(704.6)	= GROUND SURFACE ELEVATION (FT.)
	BM = BENCH MARK (FINISH FLOOR OF EXISTING BUILDING)

NOTES:

- BORINGS, BUILDINGS, SITE FEATURES, PROPERTY LINE LOCATIONS, AND SCALE OF DRAWING ARE APPROXIMATE.
- BASE MAP REFERENCE, BENCH MARK ELEVATION, AND BORING LOCATIONS PROVIDED BY NUSSBAUMER & CLARKE, INC., TITLED "PROPOSED GRADING AND UTILITY PLAN", SHEET NO. 3 OF 6, C-102, PROJECT NO. 18J5-0040, DATED 11/6/2018.

BARRON & ASSOCIATES, P.C. & BUFFALO DRILLING COMPANY
 10440 MAIN ST.
 CLARENCE, NY 14031
 (716)759-7821
 FAX (716)759-7823
 INFO@BUFFALODRILLING.COM
 INFO@BARRONANDASSOCIATESPC.COM

CLIENT: WEST HERR AUTOMOTIVE GROUP
 3552 SOUTHWESTERN BOULEVARD
 ORCHARD PARK, NEW YORK 14127

PROJECT: PROPOSED BODY SHOP ADDITION TO WEST HERR TOYOTA
 8129 MAIN STREET
 TOWN OF CLARENCE, ERIE CO., NEW YORK 14221

TEST BORING LOCATION PLAN	
JOB NO.: 18-603	SCALE: 1" = 50' ±
DATE: 12/4/2018	FIGURE NO. 2

DRAWN: DAN KASPROWICZ

**BARRON & ASSOCIATES, P.C. &
BUFFALO DRILLING COMPANY, INC.**



10440 MAIN STREET
CLARENCE, NEW YORK 14031
(716) 759-7821 FAX: (716) 759-7823

TEST BORING LOG

JOB No.: 18-603

BORING No.: B-1

PROJECT: Proposed Body Shop Addition to West Herr Toyota
8129 Main Street, Town of Clarence, Erie County, New York 14221

DRILLER: J. Gardner

TYPE OF DRILL RIG: Diedrich D-50 (Truck)

SAMPLING METHODS: ASTM D1586

SIZE AND TYPE OF BIT: 2 1/4" I.D. H.S.A.

DATE STARTED: 12/7/18

SURFACE ELEVATION (ft.): 704.8

DATE COMPLETED: 12/7/18

GROUNDWATER DEPTH (ft.): None
(measured at completion unless indicated below)

Elevation/ Depth (feet)	Soil Symbols Sampler Symbols Field Test Data	Sample No. : Range	N- Value	% REC (RQD)	Soil and Rock Description / Remarks
0					Asphalt (3")
		S-1 : 0.5'- 2.0'	14	40	Dk. gray, m. dense Gravel and Slag fragments, tr. Silt, moist (GW-Fill) Brown, m. dense f/c SAND, some to and Silt, tr. Gravel, tr. Clay, tr. Roots, non-plastic, moist (SM)
		S-2 : 2.0'- 4.0'	19	70	Brown, v. stiff CLAY, some Silt, little Gravel, little f/c Sand, mod. plastic, moist (CL/ML-Till)
		S-3 : 4.0'- 4.1'	50+	0	...grade: hard (No Recovery)
700	REFUSAL				Depth to Bottom of Hole: 4.2 feet
695					
690					
685					
680					
675					
670					

**BARRON & ASSOCIATES, P.C. &
BUFFALO DRILLING COMPANY, INC.**



10440 MAIN STREET
CLARENCE, NEW YORK 14031
(716) 759-7821 FAX: (716) 759-7823

TEST BORING LOG

JOB No.: 18-603

BORING No.: B-2

PROJECT: Proposed Body Shop Addition to West Herr Toyota
8129 Main Street, Town of Clarence, Erie County, New York 14221

DRILLER: J. Gardner

TYPE OF DRILL RIG: Diedrich D-50 (Truck)

SAMPLING METHODS: ASTM D1586

SIZE AND TYPE OF BIT: 2 1/4" I.D. H.S.A.

DATE STARTED: 12/7/18

SURFACE ELEVATION (ft.): 704.6

DATE COMPLETED: 12/7/18

GROUNDWATER DEPTH (ft.): None
(measured at completion unless indicated below)

Elevation/ Depth (feet)	Soil Symbols Sampler Symbols Field Test Data	Sample No. : Range	N- Value	% REC (RQD)	Soil and Rock Description / Remarks
0					Asphalt (3")
		S-1 : 0.5'- 2.0'	16	50	Dk. gray, m. dense Gravel and Slag fragments, tr. Silt, moist (GW-Fill)
		S-2 : 2.0'- 2.9'	50+	75	Brown, hard CLAY, some Silt, little Gravel, little f/c Sand, mod. plastic, moist (CL/ML-Till)
700	REFUSAL				Depth to Bottom of Hole: 3.2 feet
695					
690					
685					
680					
675					
670					

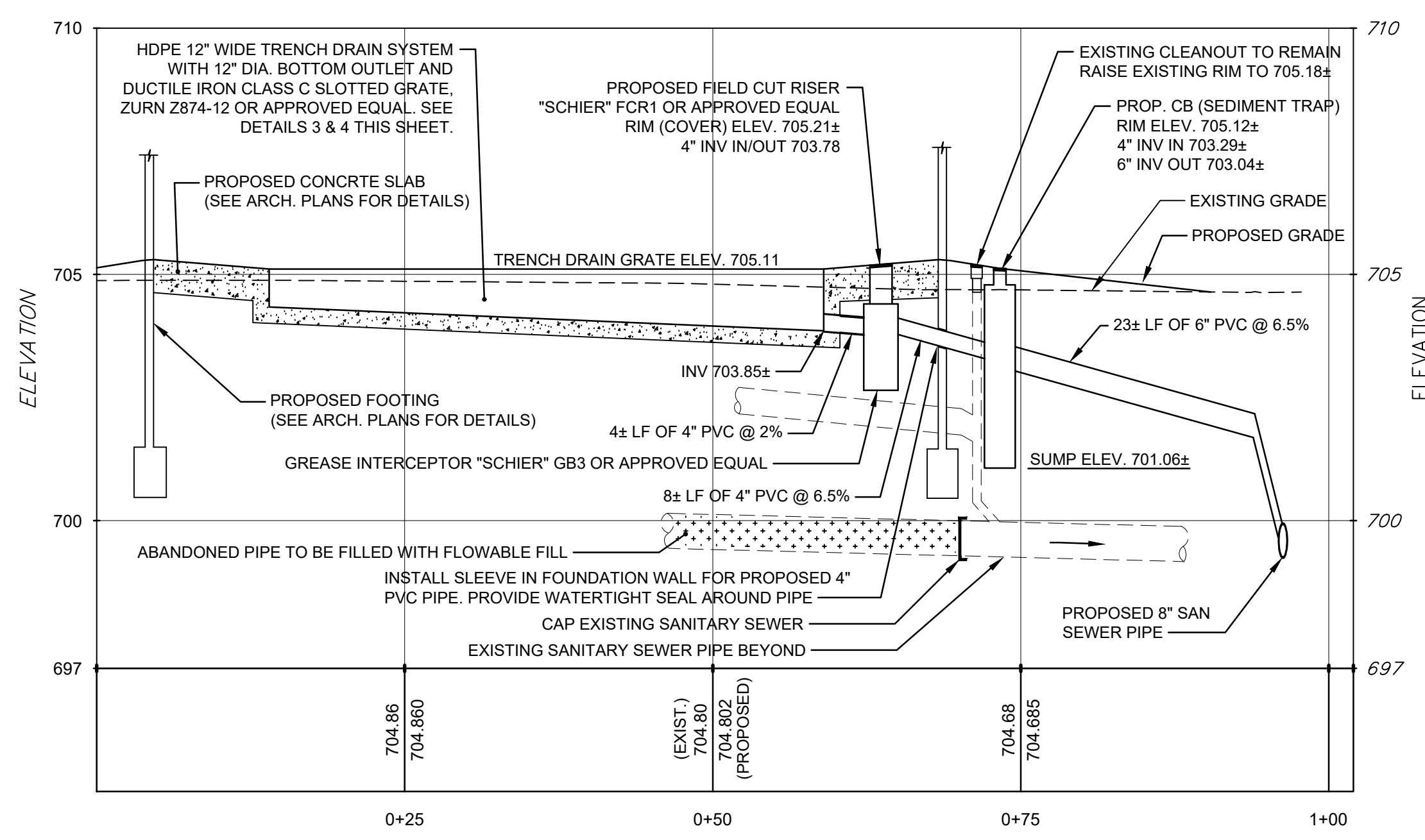

5 TRENCH DRAIN PROFILE
SCALE: NOT TO SCALE

- NOTES REQUIRED ON PLANS
- A. "The contractor is advised a trench shield and/or shoring designed in accordance with OSHA Standards shall be used in all open trench excavations".
 - B. "Any contractor and/or plumber performing work in a confined space (i.e. manholes, wetwells, chambers) owned by an Erie County Sewer District, must certify to the County that they have their own Confined Space Entry Program that meets or exceeds OSHA's regulations. Certification must be notarized by a notary public".
 - C. "Construction shall conform to the Rules and Regulations for Erie County Sewer Districts".
 - D. If any proposed sewer lateral runs under paved area and has more than four (4) feet of cover, then on site plan and profile hatchmark and label, "select fill required" in affected areas.
 - E. The contractor must contact the District Office 48 hours in advance of construction.
 - F. Vents must be installed six (6) inches above grade, in a grassy area with a mushroom cap. If the vent is in a sidewalk or paved area, then protect with bollards (3 minimum).
 - G. Cleanouts (c.o) are required every one hundred feet (100') and at change of direction.
 - H. Abandoned sanitary sewer connections from the site, if any, require proof of a District Permit for Disconnection prior to the new connection being made.
 - I. Reuse of existing building sewers shall conform to the Rules and Regulations for ECSD, Article III, Section 304.

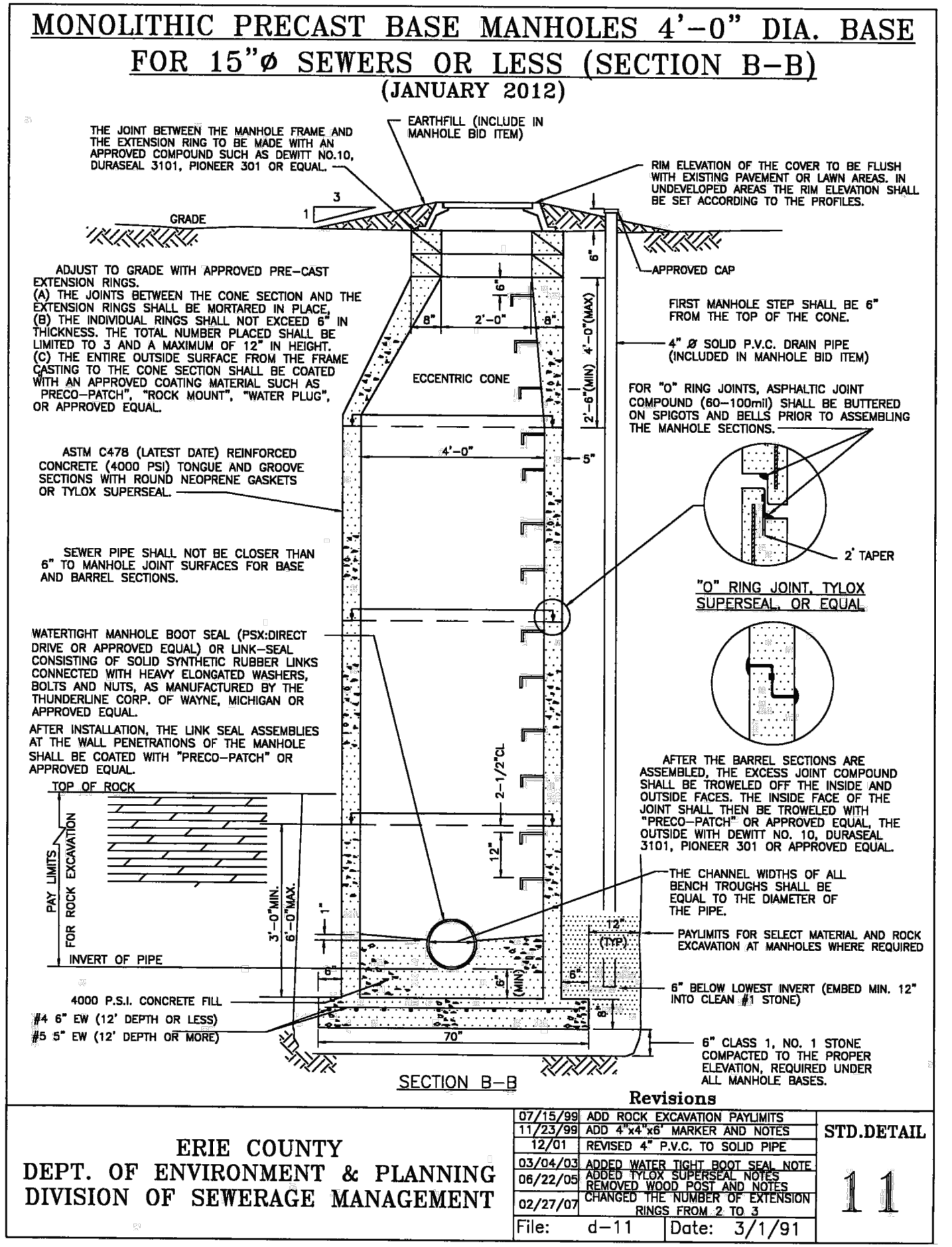

1 TYPICAL MANHOLE DETAIL
SCALE: NOT TO SCALE

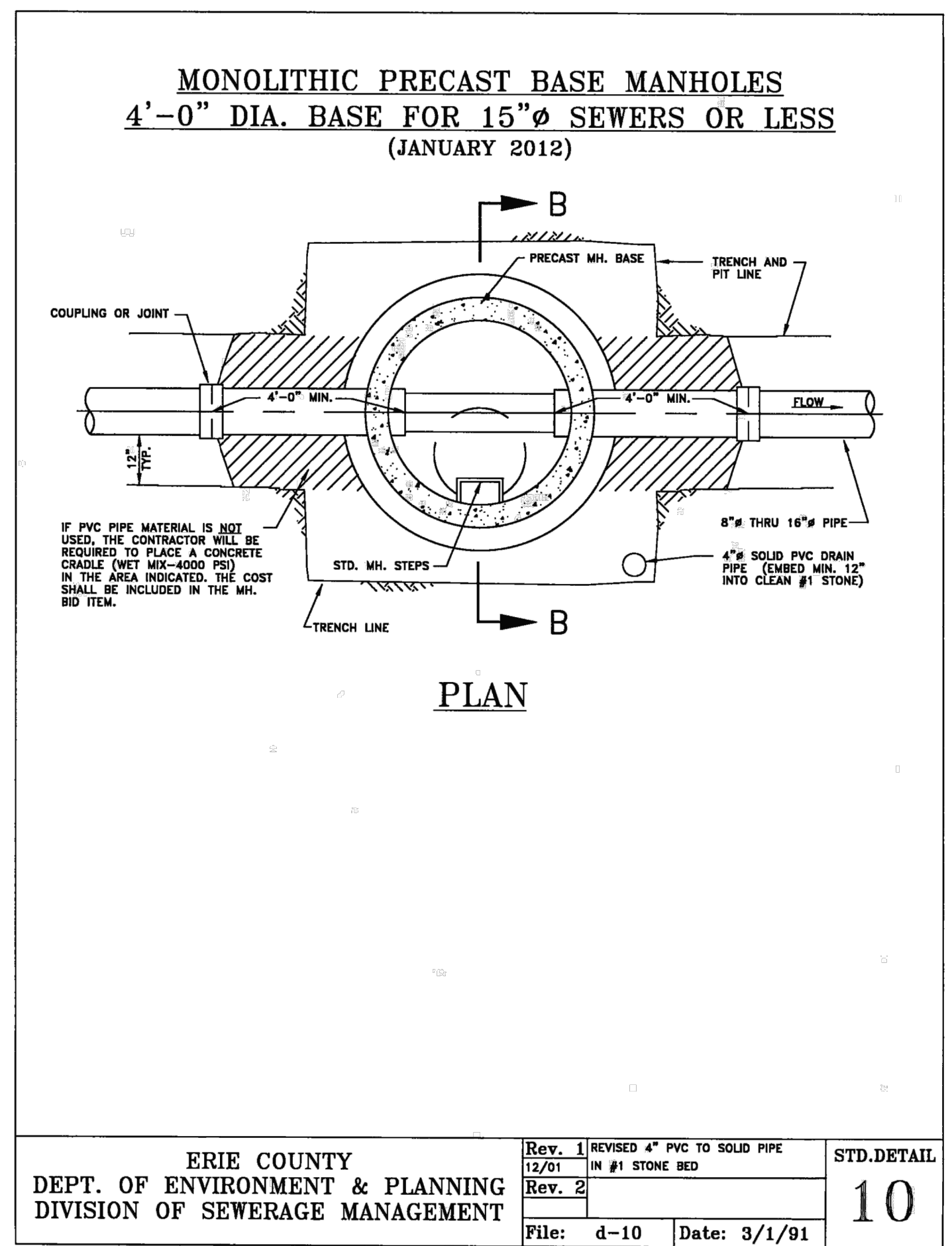

2 TYPICAL MANHOLE BASE DETAIL
SCALE: NOT TO SCALE

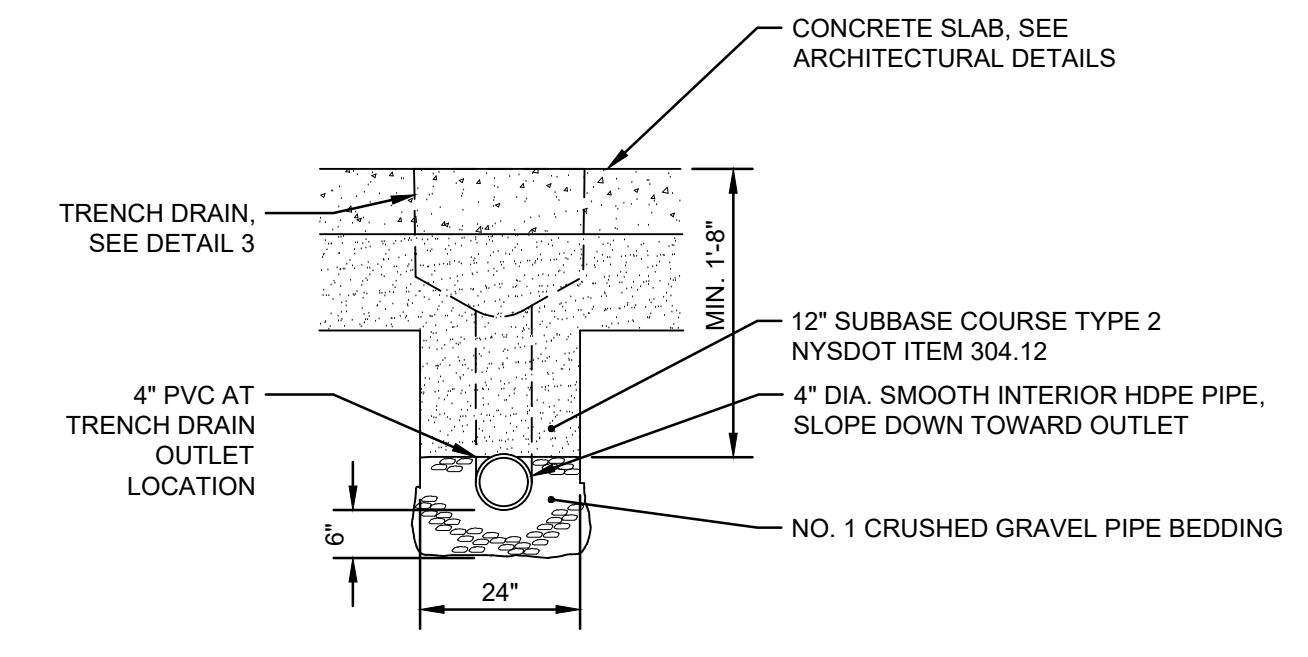

4 TRENCH DRAIN - PIPE TRENCH DETAIL
SCALE: NOT TO SCALE

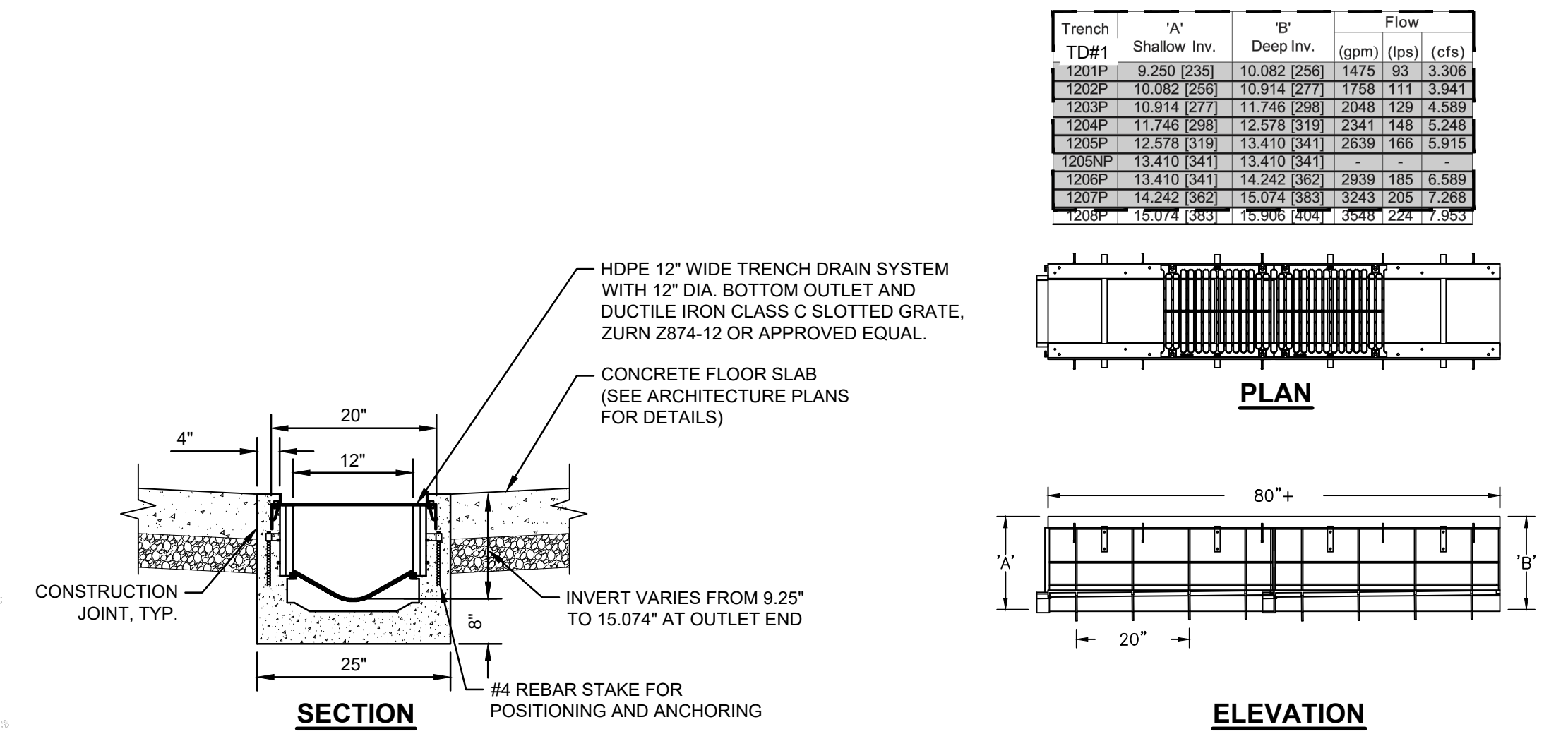

3 TRENCH DRAIN DETAIL (ZURN Z874-12)
SCALE: NOT TO SCALE

Trench TD#1	'A' Shallow Inv.	'B' Deep Inv.	Flow (gpm)	Flow (lps)	Flow (cfs)
1201P	9.250 (235)	10.082 (256)	1475	89	3.306
1202P	10.082 (256)	10.914 (277)	1758	111	3.941
1203P	10.914 (277)	11.746 (298)	2048	129	4.589
1204P	11.746 (298)	12.578 (319)	2341	148	5.248
1205P	12.578 (319)	13.410 (341)	2639	166	5.915
1205NP	13.410 (341)	13.410 (341)	-	-	-
1206P	13.410 (341)	14.242 (362)	2939	185	6.589
1207P	14.242 (362)	15.074 (383)	3243	205	7.288
1208P	15.074 (383)	15.906 (404)	3548	224	7.953



REGULATORY REVIEW
NOT FOR CONSTRUCTION

WEST HERR TOYOTA BODY SHOP
ADDITION
8129 MAIN STREET, CLARENCE, NY
SITE DETAILS 2 OF 2

REVISIONS		
No.	DESCRIPTION	DATE
1	REVISED TRENCH DRAIN PROFILE	12.10.18

NUSSBAUMER & CLARKE, INC.
A CORPORATION REGISTERED TO
PRACTICE PROFESSIONAL ENGINEERING
& LAND SURVEYING IN THE
STATE OF NEW YORK

UNAUTHORIZED ALTERATION OR ADDITION TO THIS
ENGINEERING DRAWING IS A VIOLATION OF
SECTION 7209, PROVISION 2 OF THE NEW YORK STATE
EDUCATION LAW.

PROJECT NUMBER	18J5-0040
DATE	11.26.18
DRAWN BY	TJB
DESIGNED BY	TJB
CHECKED BY	RJP
APPROVED BY	BLS
SCALE:	AS NOTED
= 1 INCH	
SHEET No.	5 OF 8

C-104



SCHIER

**LIFETIME GUARANTEED
GREASE INTERCEPTORS**

INSTALLATION GUIDE

Model FCR1 Field Cut Riser

For Use with Grease Interceptors Models GB1, GB2 and GB3

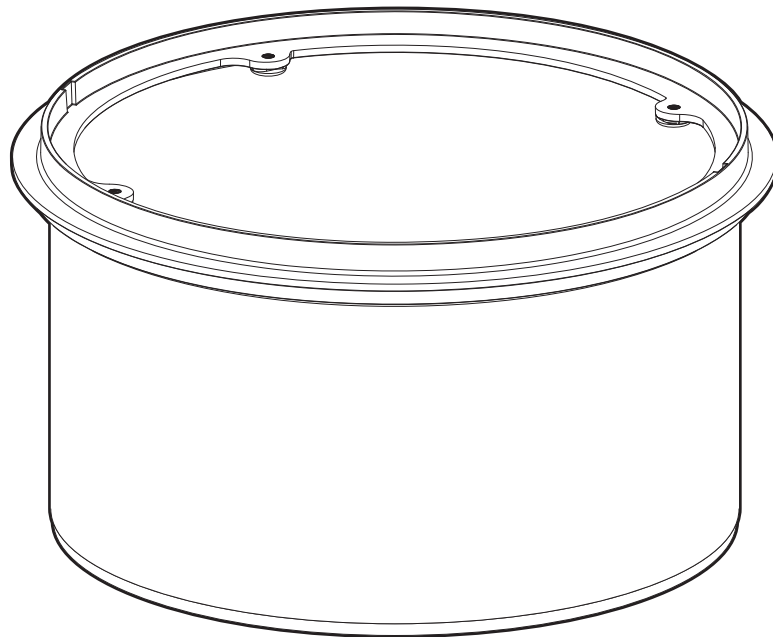

Contents

Special Precautions	2
Getting to Know the FCR1	3
Installation	4-5



SPECIAL PRECAUTIONS

For All Schier Grease Interceptor Installations - Failure to follow this guidance voids your warranty

Installation Instructions

Installation instructions and additional components are included with the interceptor. Read all instructions prior to installation. This interceptor is intended to be installed by a licensed plumber in conformance with all local codes.

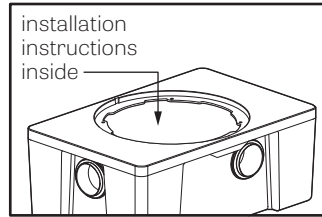

When Installing Interceptor Inside

If your dishwashing sink(s) discharges into a floor drain/sink (drain), you must regulate the flow into the drain to avoid an overflow of water onto the kitchen floor. This can be done by installing a valve or flow restriction cap on the sink piping that discharges into the drain. See drawing above for guidance. For detailed guidance on indirect connections, go to:

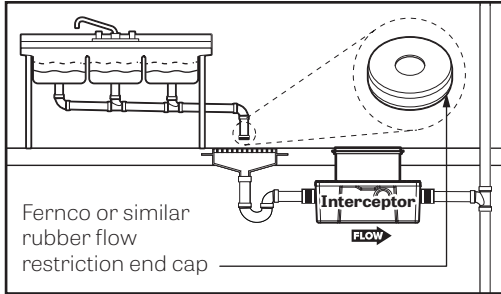

http://webtools.schierproducts.com/Technical_Data/Indirect_Connections.pdf

Flush-to-Grade Burials

Flush-to-Grade buried installations (without a riser) are not recommended for heavy foot traffic areas without the use of an internal support system (sold additionally).

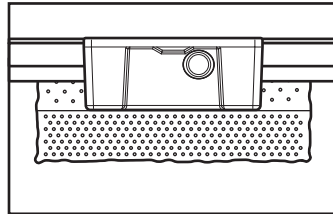

High Temperature Kitchen Water

If water is entering the interceptor at excessive temperature (over 140° F), a drain water tempering valve (DTV) and approved backflow prevention assembly must be installed. Most state and local plumbing codes prohibit water above 140° F being discharged into the sanitary sewer. Water above 140° F will weaken or deform PVC Schedule 40 pipe, poly drainage fixtures like interceptors and erode the coating of cast iron (leading to eventual failure).

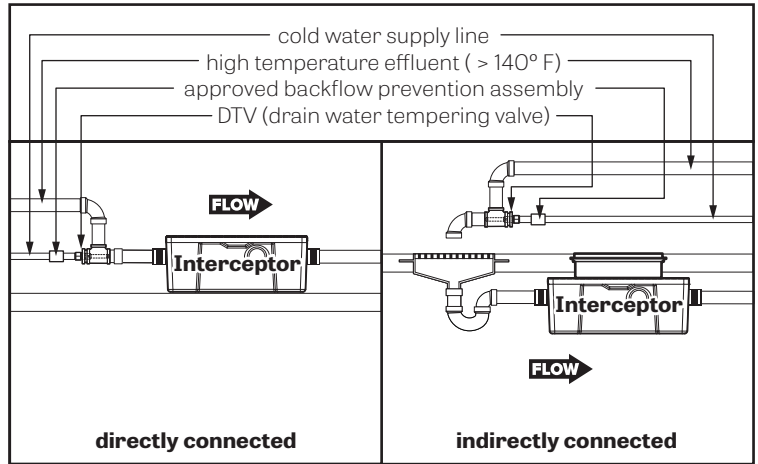

Fully Support Base of Unit

Install unit on solid, level surface in contact with the entire footprint of unit base; for suspended installations design trapeze to support the wet weight of the unit. Do not partially support unit or suspend unit using metal U-channel to create a trapeze

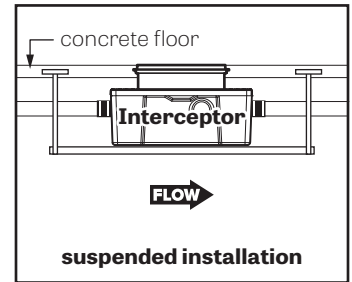

Support Inlet and Outlet Piping

For above grade installations ensure heavy inlet and outlet piping (such as cast iron or long runs) is properly supported or suspended during the entire installation process to prevent connection failure or damage to bulkhead fittings.

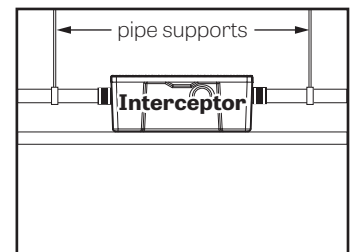

GETTING TO KNOW THE FCR1

Take a few moments to familiarize yourself with the FCR1.

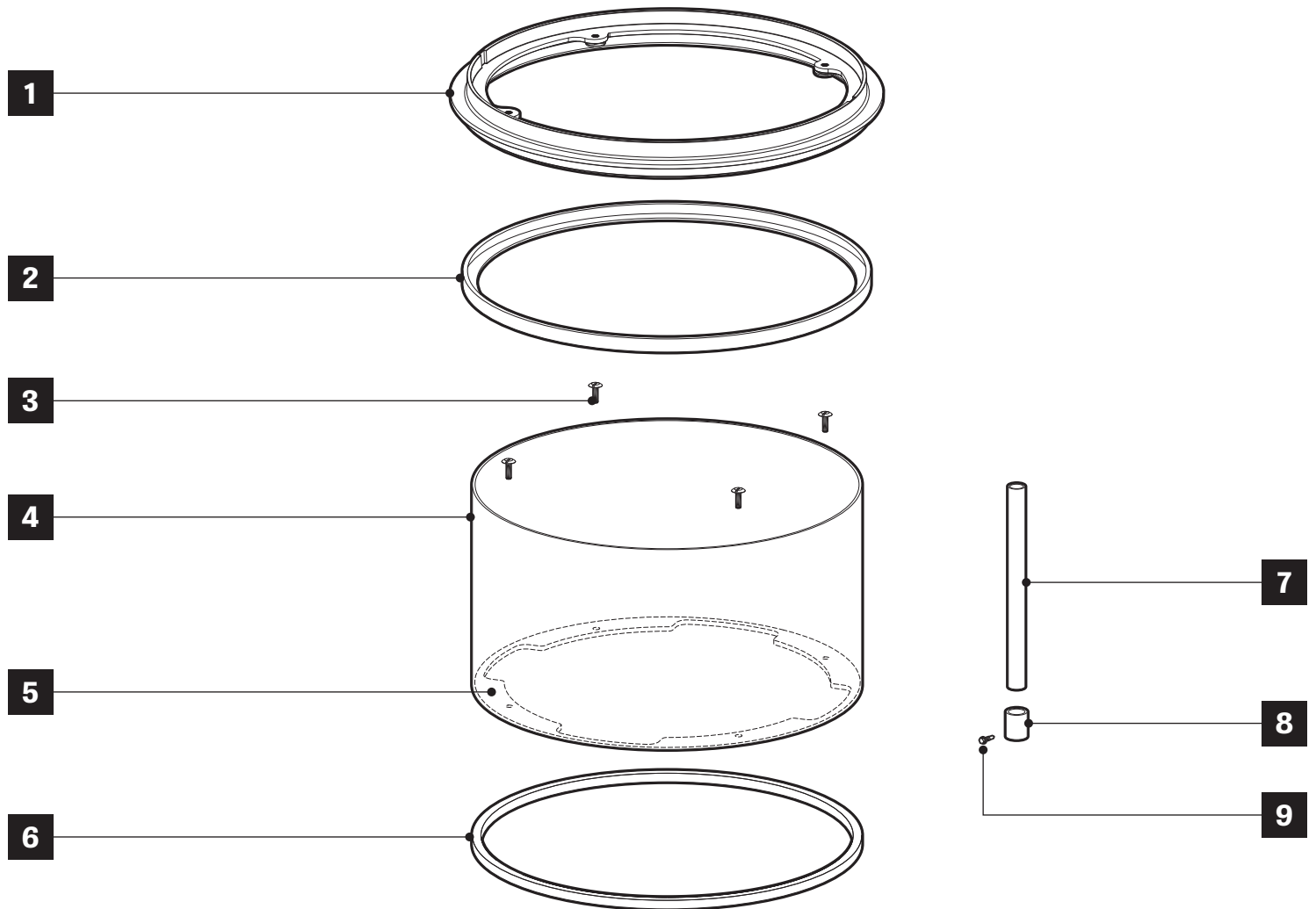

1. Cover Ring
2. Cover Ring Gasket
3. Riser Mounting Bolts
4. Riser Body
5. Riser Mounting Flange
6. Riser Body Gasket
7. Diffuser Access Riser (x2)
8. Diffuser Access Coupling (x2)
9. Diffuser Access Set Screw (x2)

INSTALLATION

Special Precautions

1

 **CAUTION**

Do not add any form of lubricant to riser tube during installation.

2

- Read all instructions before installation
- Install in conformance with all local codes

3

Max Water Level
Risers are not designed to retain water

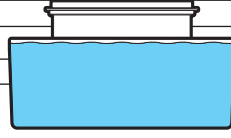

1 Determine number of risers needed

1a

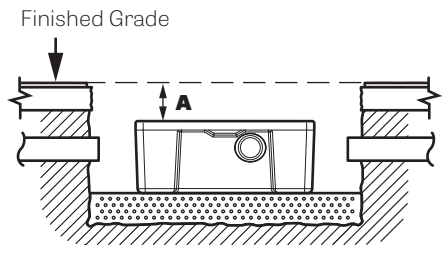

Finished Grade

A

1b

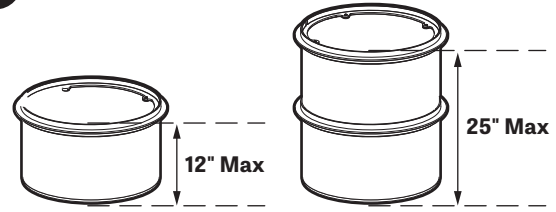

12" Max

25" Max

1 Riser

2 Risers

For the interceptor to be safely and properly maintained, dimension **A** cannot exceed 25" (or two FCRI risers stacked).

2 Mark and cut top-most riser

2a

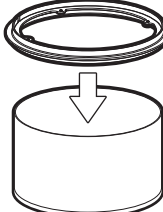

Push cover ring onto riser body until it stops (about 1").

2b

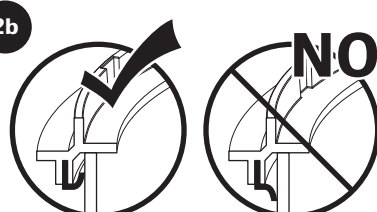

Ensure cover ring gasket is positioned as shown

2c

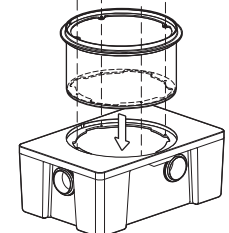

Place riser on interceptor, aligning bolt holes

2d

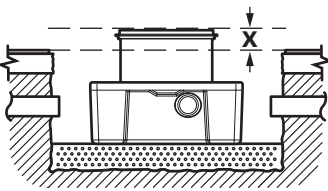

Measure "X" with tape measure.

2e

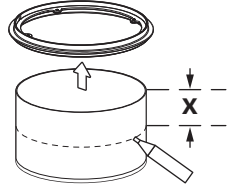

Remove cover ring from riser assembly and mark "X" with supplied grease pencil.

2f

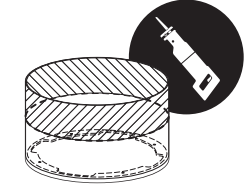

Cut "X" from top of riser and discard.

3 Fasten diffuser access risers

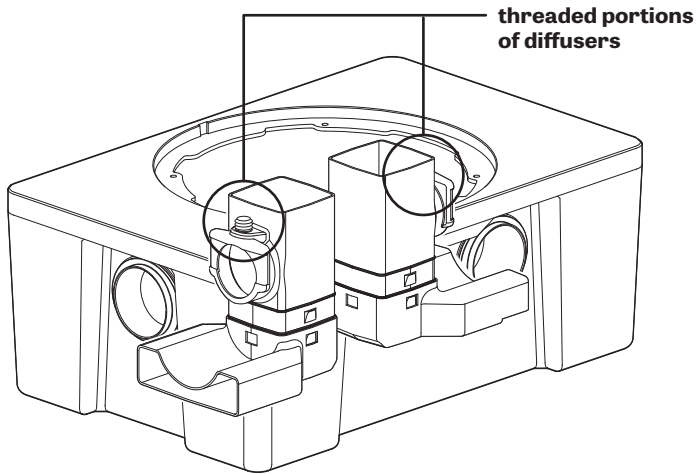

Push the diffuser access coupling onto the threaded portion of each diffuser and set using supplied set screw. Glue the diffuser access riser to each coupling.

NOTE: If stacking two FCR1 risers, you may also stack two diffuser access risers.

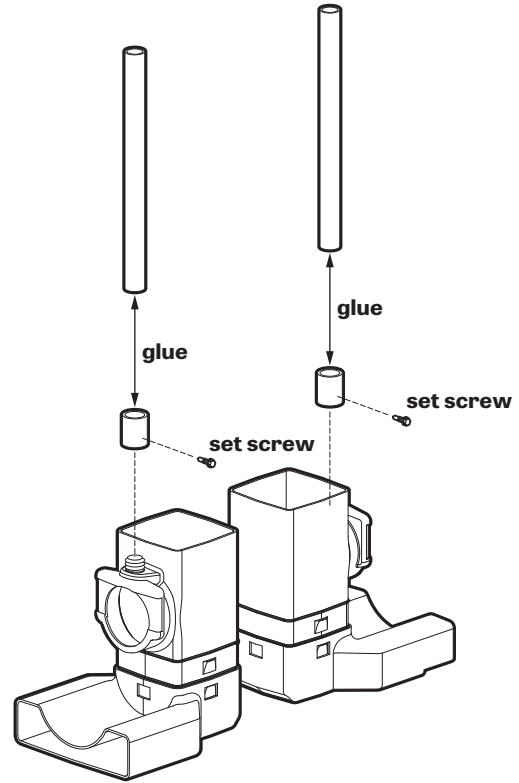

4 Fasten riser to interceptor

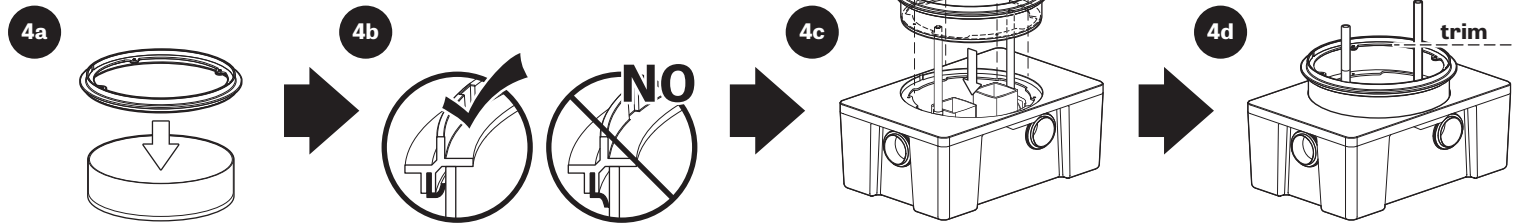

Remove any burrs or debris at the cut edge. Push cover ring onto riser body until it stops (about 1").

Ensure cover ring gasket is positioned as shown.

Place riser on interceptor, aligning bolt holes and fasten securely with mounting bolts.

Trim off excess from diffuser access risers.

5 Prepare for backfill

Resume "Buried Installation" instructions for applicable unit (GB1, GB2 or GB3)

FCR1

field cut riser system

For Use with Grease Interceptors

Models GB1, GB2 and GB3

Specification

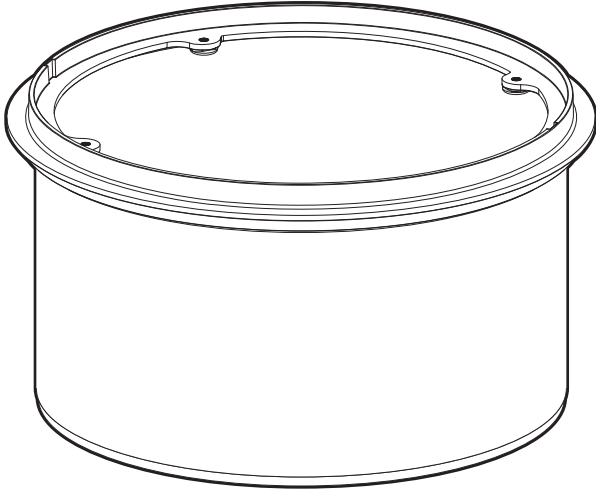

Notes

1. Rotationally molded polyethylene body
2. Injection molded polypropylene top cover ring
3. EPDM sponge tank-to-riser gasket
4. Silicone fin riser body to riser top gasket
5. Unit weight: 10 lbs.
6. Risers not designed to hold water

Engineer Specification Guide:

Field-cut adjustable riser system to consist of rotationally molded polyethylene body, injection molded polypropylene top cover ring, EPDM sponge gasket at bottom, silicone fin gasket at top flange. Risers shall allow field adjustability of cover to grade.

Installation Note

Minimum install height: 2-1/8". Maximum install height: 12". Riser system may be stacked no more than two units high to a maximum of 25" extension. Access to internal components will not be compromised.

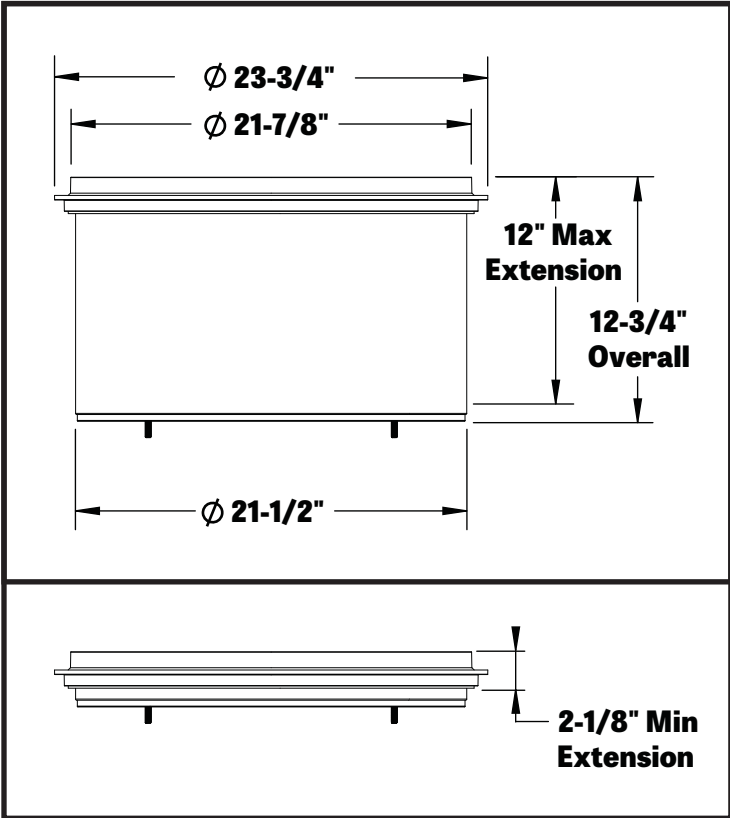

SCHIER
LIFETIME GUARANTEED
GREASE INTERCEPTORS

MODEL NUMBER:
FCR1

DESCRIPTION: 12" Field Cut Riser Extension System

PART #: 8010-005-01

DWG BY: B. Karrer

DATE: 5/4/2017

REV:

ECO:



SPECIAL PRECAUTIONS

For All Schier Grease Interceptor Installations - Failure to follow this guidance voids your warranty

Installation Instructions

Installation instructions and additional components are included with the interceptor. Read all instructions prior to installation. This interceptor is intended to be installed by a licensed plumber in conformance with all local codes.

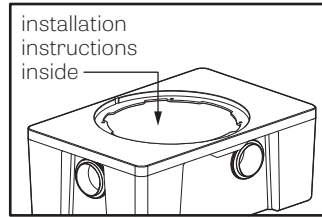

When Installing Interceptor Inside

If your dishwashing sink(s) discharges into a floor drain/sink (drain), you must regulate the flow into the drain to avoid an overflow of water onto the kitchen floor. This can be done by installing a valve or flow restriction cap on the sink piping that discharges into the drain. See drawing above for guidance. For detailed guidance on indirect connections, go to:

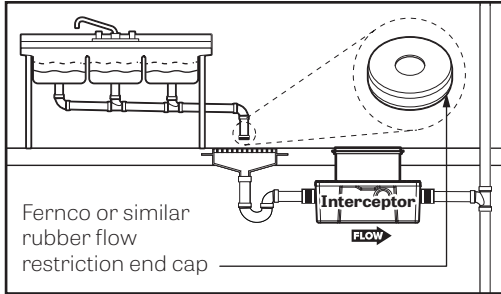

http://webtools.schierproducts.com/Technical_Data/Indirect_Connections.pdf

Flush-to-Grade Burials

Flush-to-Grade buried installations (without a riser) are not recommended for heavy foot traffic areas without the use of an internal support system (sold additionally).

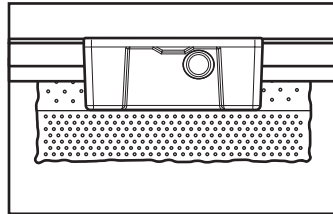

High Temperature Kitchen Water

If water is entering the interceptor at excessive temperature (over 140° F), a drain water tempering valve (DTV) and approved backflow prevention assembly must be installed. Most state and local plumbing codes prohibit water above 140° F being discharged into the sanitary sewer. Water above 140° F will weaken or deform PVC Schedule 40 pipe, poly drainage fixtures like interceptors and erode the coating of cast iron (leading to eventual failure).

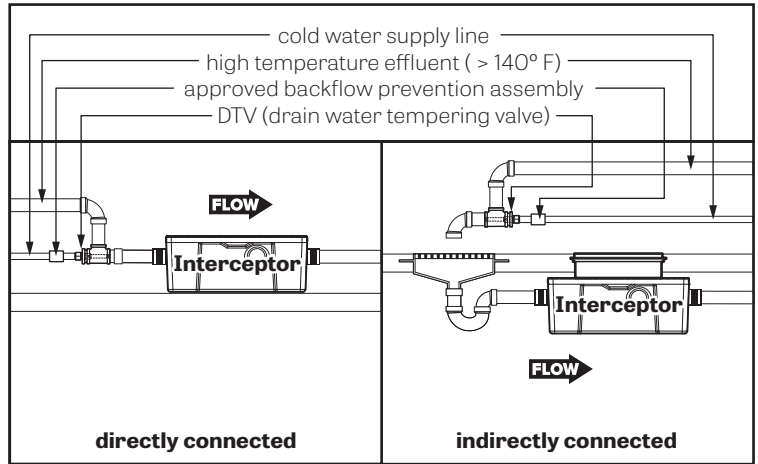

Fully Support Base of Unit

Install unit on solid, level surface in contact with the entire footprint of unit base; for suspended installations design trapeze to support the wet weight of the unit. Do not partially support unit or suspend unit using metal U-channel to create a trapeze

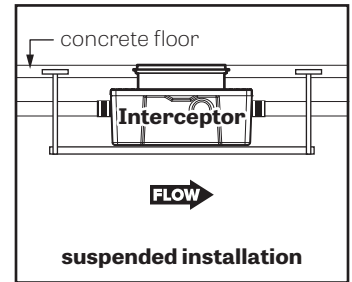

Support Inlet and Outlet Piping

For above grade installations ensure heavy inlet and outlet piping (such as cast iron or long runs) is properly supported or suspended during the entire installation process to prevent connection failure or damage to bulkhead fittings.

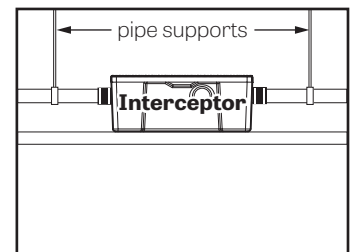

SCHIER
LIFETIME GUARANTEED
GREASE INTERCEPTORS

MODEL NUMBER:
FCR1

DESCRIPTION: 12" Field Cut Riser Extension System

PART #: 8010-005-01

DWG BY: B. Karrer

DATE: 5/4/2017

REV:

ECO:

INSTALLATION GUIDE

Model #GB3 50/75 GPM Grease Interceptor
For Indoor Use

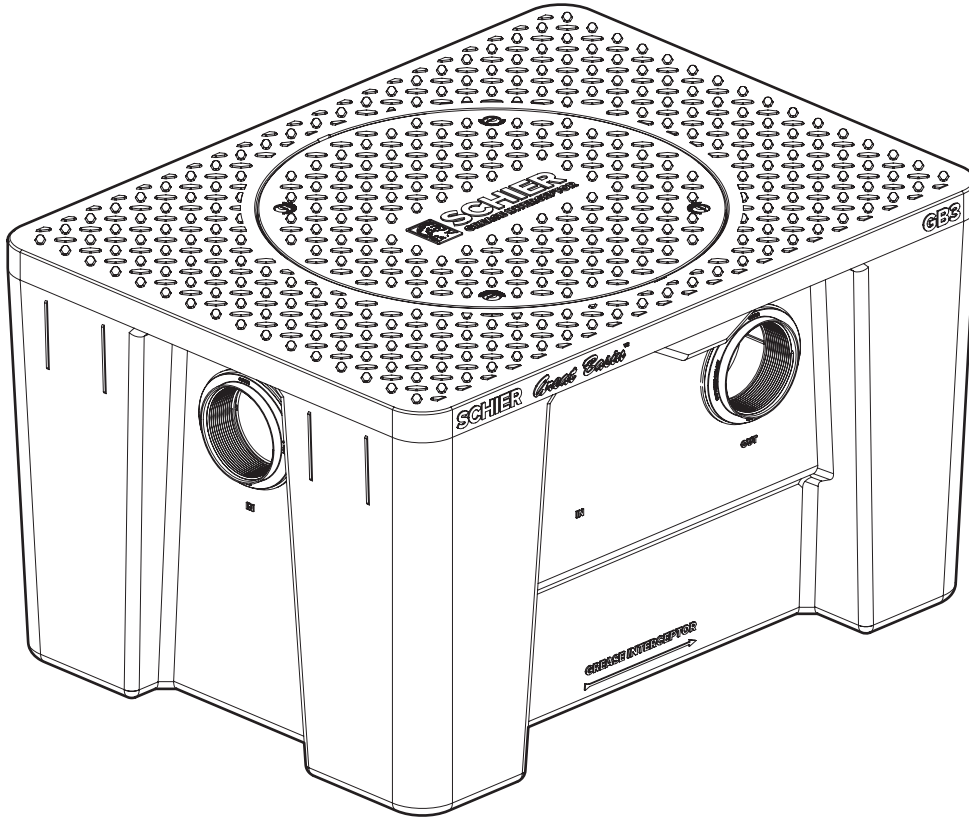

Contents

Special Precautions	2
Getting to Know the GB3	3
On the Floor Installation	4-6
Buried Installation	7-9
Installation Options	10



SCHIER
LIFETIME GUARANTEED
GREASE INTERCEPTORS



SPECIAL PRECAUTIONS

For All Schier Grease Interceptor Installations - Failure to follow this guidance voids your warranty

Installation Instructions

Installation instructions and additional components are included with the interceptor. Read all instructions prior to installation. This interceptor is intended to be installed by a licensed plumber in conformance with all local codes.

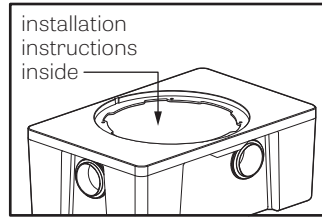

When Installing Interceptor Inside

If your dishwashing sink(s) discharges into a floor drain/sink (drain), you must regulate the flow into the drain to avoid an overflow of water onto the kitchen floor. This can be done by installing a valve or flow restriction cap on the sink piping that discharges into the drain. See drawing above for guidance. For detailed guidance on indirect connections, go to:

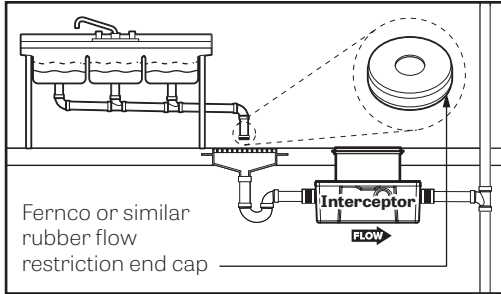

http://webtools.schierproducts.com/Technical_Data/Indirect_Connections.pdf

Flush-to-Grade Burials

Flush-to-Grade buried installations (without a riser) are not recommended for heavy foot traffic areas without the use of an internal support system (sold additionally).

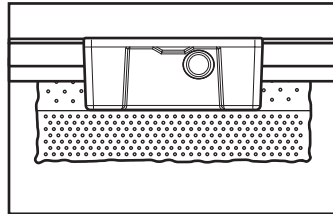

High Temperature Kitchen Water

If water is entering the interceptor at excessive temperature (over 140° F), a drain water tempering valve (DTV) and approved backflow prevention assembly must be installed. Most state and local plumbing codes prohibit water above 140° F being discharged into the sanitary sewer. Water above 140° F will weaken or deform PVC Schedule 40 pipe, poly drainage fixtures like interceptors and erode the coating of cast iron (leading to eventual failure).

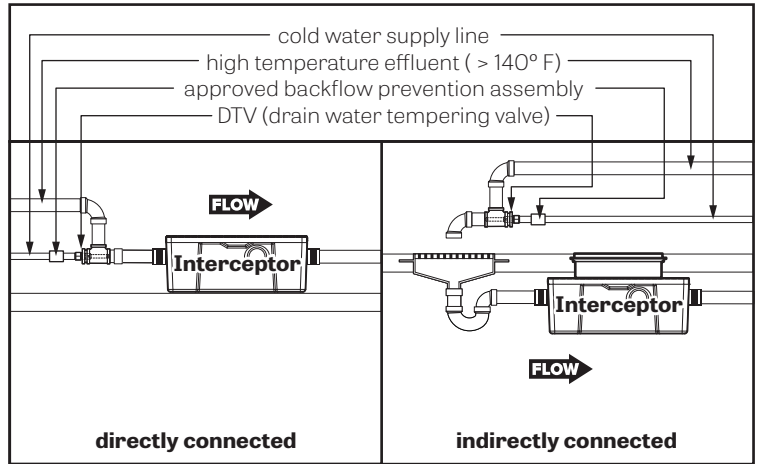

Fully Support Base of Unit

Install unit on solid, level surface in contact with the entire footprint of unit base; for suspended installations design trapeze to support the wet weight of the unit. Do not partially support unit or suspend unit using metal U-channel to create a trapeze

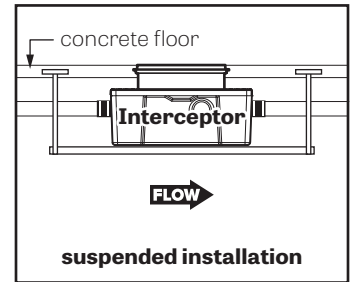

Support Inlet and Outlet Piping

For above grade installations ensure heavy inlet and outlet piping (such as cast iron or long runs) is properly supported or suspended during the entire installation process to prevent connection failure or damage to bulkhead fittings.

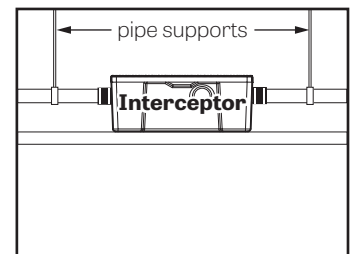

ON THE FLOOR INSTALLATION

Special Precautions

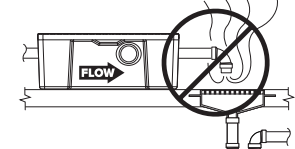
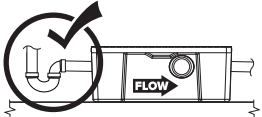
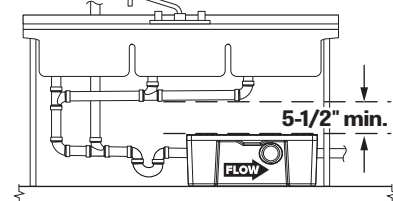
<p>1</p> <p>! WARNING!</p> <p>DO NOT AIR TEST UNIT OR RISER SYSTEM!</p> <p>Doing so may result in property damage, personal injury or death.</p>	<p>2</p> <ul style="list-style-type: none"> <input type="checkbox"/> Read all instructions before installation <input type="checkbox"/> Install in conformance with all local codes 	<p>3 Install interceptor as close as possible to fixtures being served</p>
<p>4</p> <p>ODOR ALERT!</p> <p>Do not install air gap on outlet side of interceptor.</p> 	<p>5</p> <p>ODOR ALERT!</p> <p>Interceptor is not a sewer gas trap. All upstream fixtures must be trapped.</p> 	<p>6 Provide at least 5-1/2" clearance above unit for routine maintenance.</p> 

1 Test tank for water tightness

1a Cap all connection points with 4" cleanout plugs using pipe thread sealant or tape approved for use with plastics.

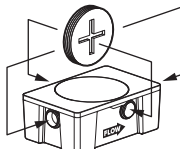

1b Remove cover and fill with water to just above the highest connection. For riser system testing (if required) fill to finished grade level. **CAUTION:** Support risers before filling to prevent tipping. Inspect unit, connections and gaskets for leaks. Check water level at specific time intervals per local code.

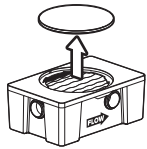

Leak?
Call customer care at 913-951-3300
8a – 5p M – F CST

2 Configure outlet diffuser and install cleanout plugs

2a Choose outlet location.



Side outlet

OR

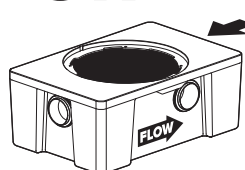

Straight-through

2b Remove diffuser from saddle.

2c Remove saddle adapter.

2d Remove set screws from foot, remove foot.

2e Install saddle adapter on desired outlet.

2f Rotate diffuser top toward desired outlet, while ensuring foot is pointed toward the back wall of the unit. Reattach foot and set screws.

2g Seat diffuser firmly into saddle.

2h Install cleanout plugs into unused outlet connections using pipe thread sealant or tape approved for use with plastics.

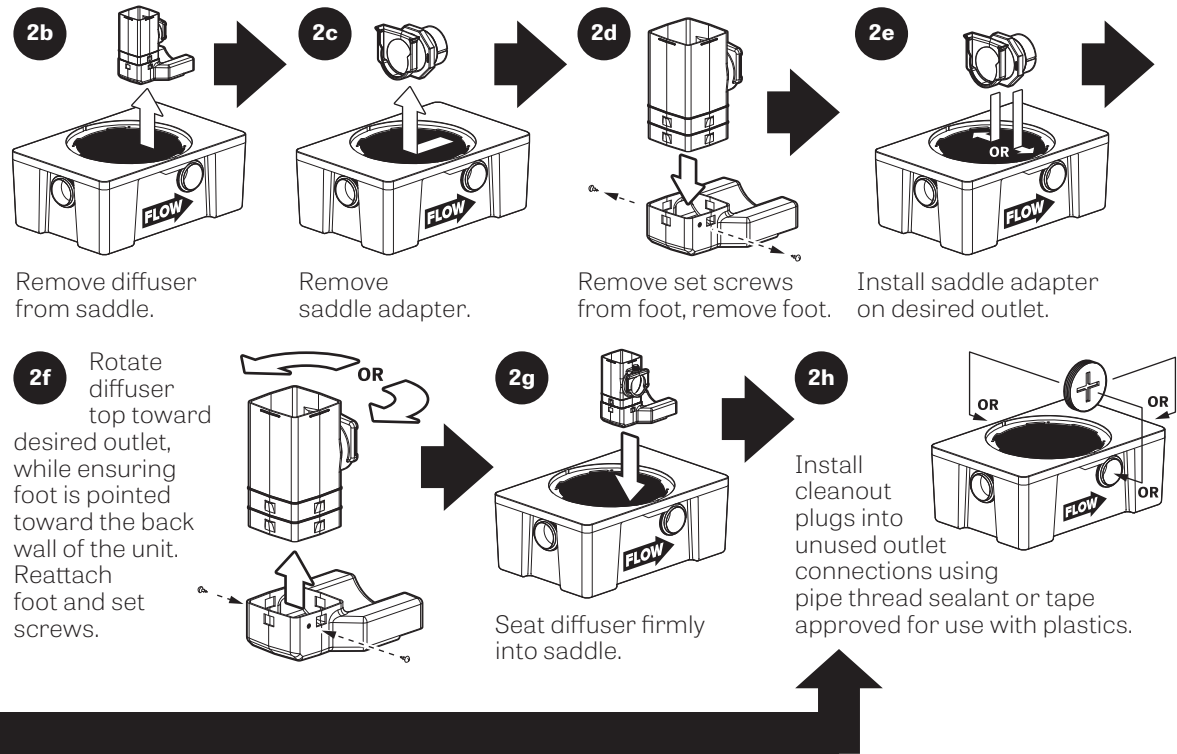

3 Calibrate Flow Control

Figure 1

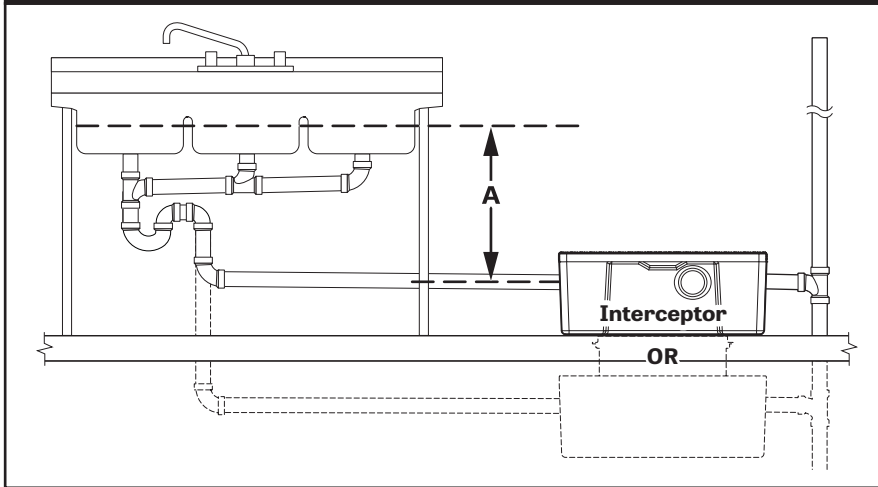

Note to Plumbing Inspector

This interceptor includes certified internal flow control and does not require a dedicated "Flow Control Vent" (air intake).

- If dimension "A" above is 5 feet or less **go to Step 4, Connect Piping.**
- If dimension "A" above is greater than 5 feet **follow Steps below.**

3a

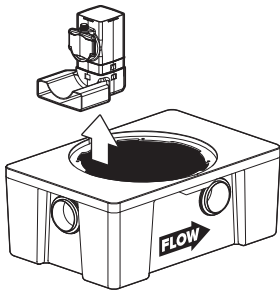

Remove inlet diffuser.

3b

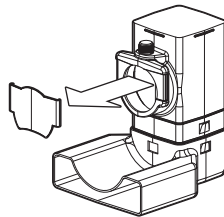

Remove red flow control plate from inlet diffuser and discard.

3c

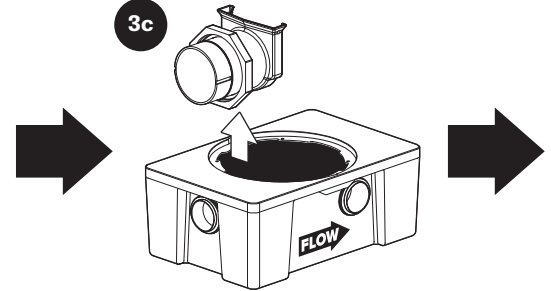

Remove inlet saddle adapter.

3d

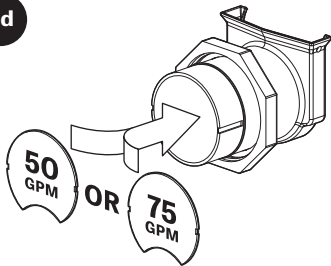

Depending on which flow rate is desired, snap-in the "50 GPM" or "75 GPM" white flow control plate as shown on inlet saddle adapter.

3e

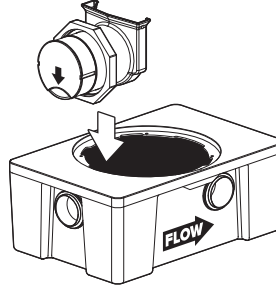

Re-install saddle adapter, ensure flow control plate opening is down as shown.

3f

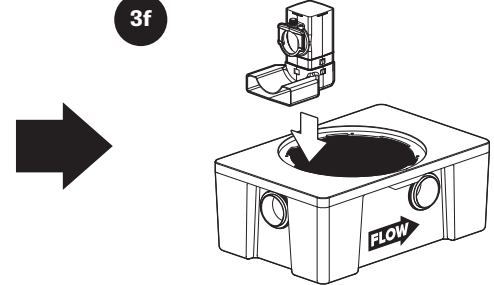

Seat inlet diffuser firmly into saddle adapter.

ON THE FLOOR INSTALLATION

4 Connect Piping

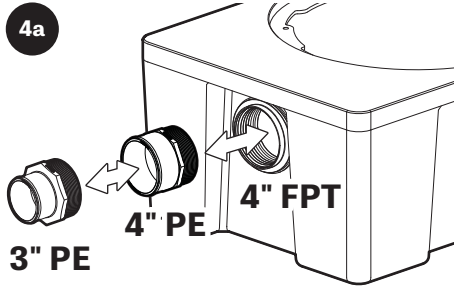

Choose inlet and outlet fittings (included) based on pipe size.

4b Connect piping using pipe thread sealant or tape approved for use with plastics. Ensure all upstream fixtures are trapped. Vent per local code.

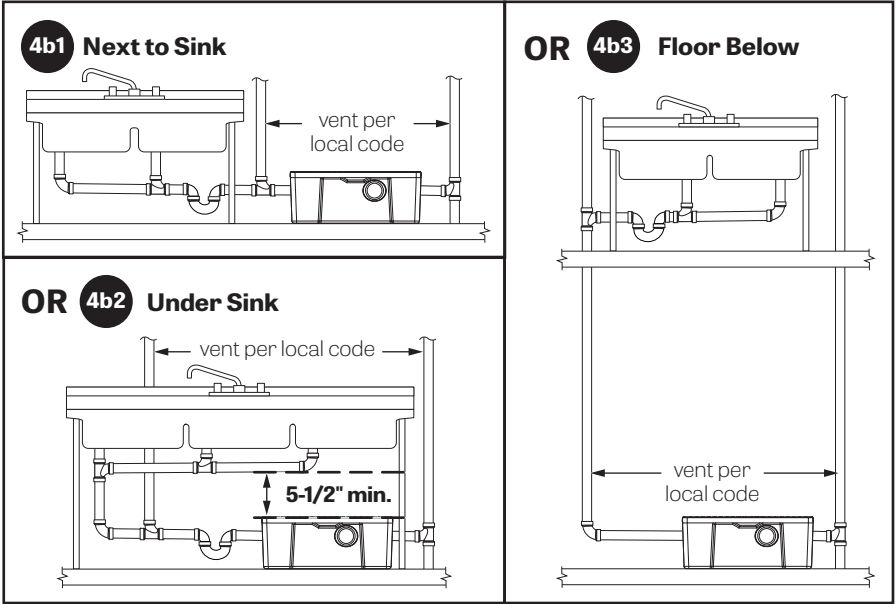

5 Wet or Air Test Piping Per Local Code

1  **WARNING! DO NOT AIR TEST UNIT OR RISER SYSTEM!**
Doing so may result in property damage, personal injury or death.



Leak? Call customer care at
913-951-3300
8a - 5p M - F CST

BURIED INSTALLATION

Special Precautions

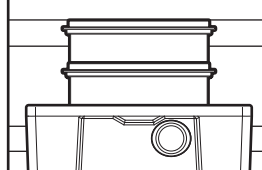
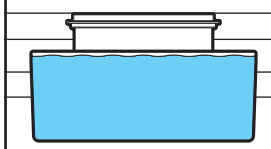
<p>1 WARNING! DO NOT AIR TEST UNIT OR RISER SYSTEM! Doing so may result in property damage, personal injury or death.</p>	<p>2 Read all instructions before installation</p> <p>Install in conformance with all local codes</p>	<p>3 Install interceptor as close as possible to fixtures being served</p>	<p>4 2 Risers (25") Max</p> 	<p>5 Max Water Level Risers are not designed to retain water</p> 
--	--	--	--	--

1 Test tank for water tightness

1a Cap all connection points with 4" cleanout plugs using pipe thread sealant or tape approved for use with plastics.

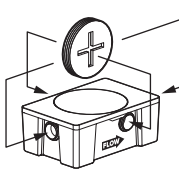

1b Remove cover and fill with water to just above the highest connection. For riser system testing (if required) fill to finished grade level. **CAUTION:** Support risers before filling to prevent tipping. Inspect unit, connections and gaskets for leaks. Check water level at specific time intervals per local code.

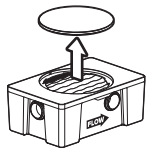

Leak?
Call customer care at 913-951-3300
8a – 5p M – F CST

2 Configure outlet diffuser and install cleanout plugs

2a Choose outlet location.

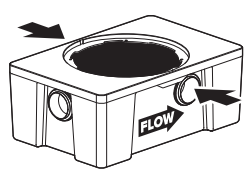

Side outlet

OR

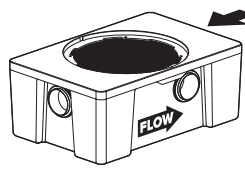

Straight-through

2b Remove diffuser from saddle.

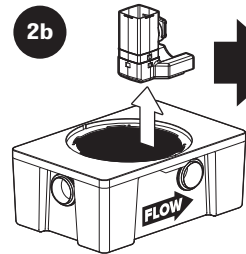

2c Remove saddle adapter.

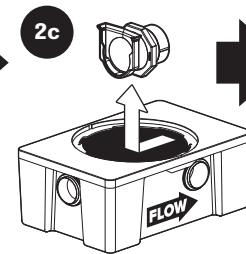

2d Remove set screws from foot, remove foot.

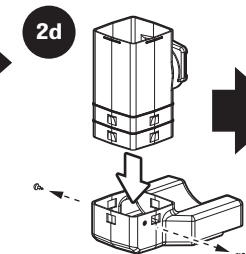

2e Install saddle adapter on desired outlet.

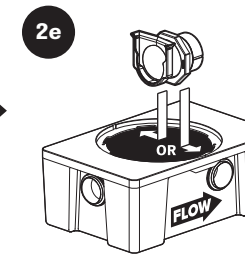

2f Rotate diffuser top toward desired outlet, while ensuring foot is pointed toward the back wall of the unit. Reattach foot and set screws.

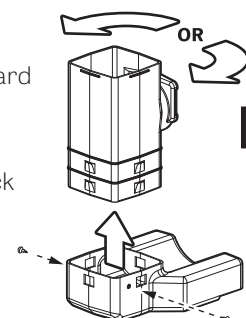

2g Seat diffuser firmly into saddle.

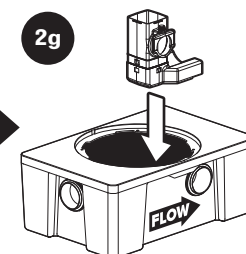

2h Install cleanout plugs into unused outlet connections using pipe thread sealant or tape approved for use with plastics.

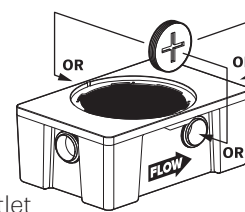

3 Calibrate Flow Control

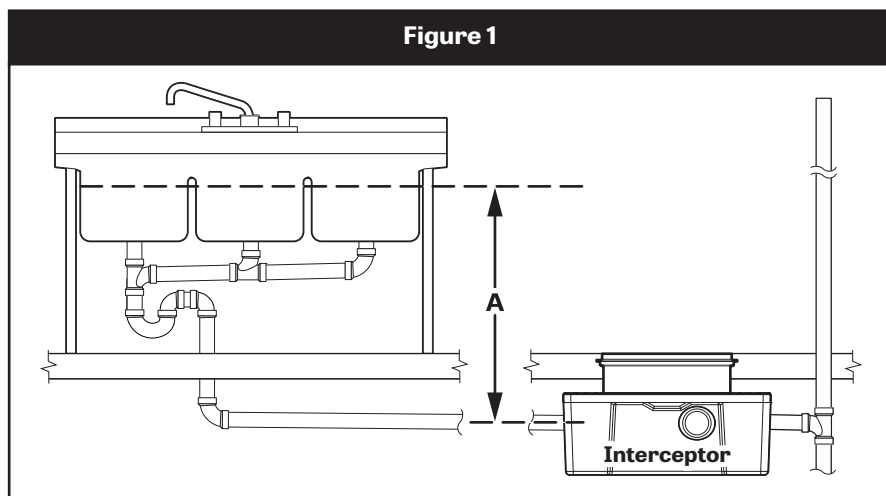

Note to Plumbing Inspector

This interceptor includes certified internal flow control and does not require a dedicated "Flow Control Vent" (air intake).

- If dimension "A" above is 5 feet or less **go to Step 4, Connect Piping**.
- If dimension "A" above is greater than 5 feet **follow Steps below**.

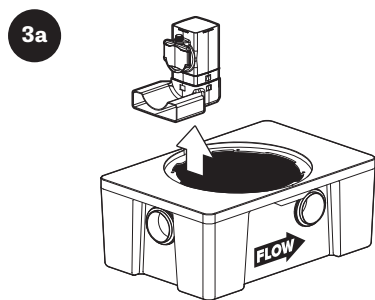

Remove inlet diffuser.

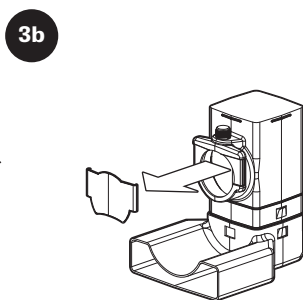

Remove red flow control plate from inlet diffuser and discard.

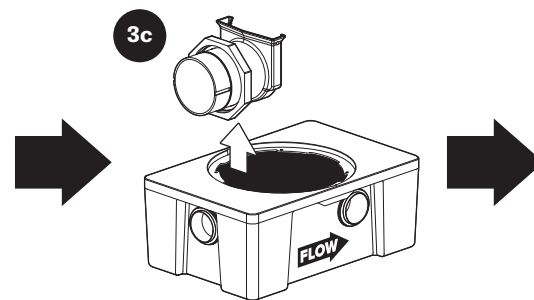

Remove inlet saddle adapter.

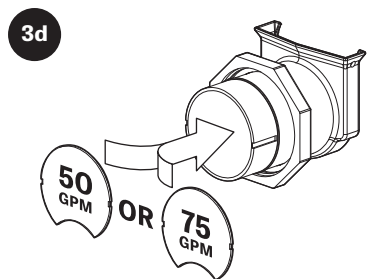

Depending on which flow rate is desired, snap-in the "50 GPM" or "75 GPM" white flow control plate as shown on inlet saddle adapter.

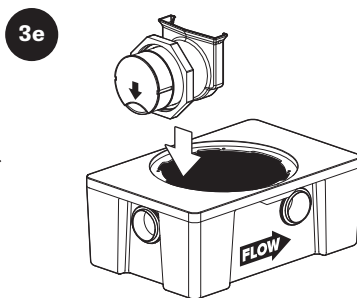

Re-install saddle adapter, ensure flow control plate opening is down as shown.

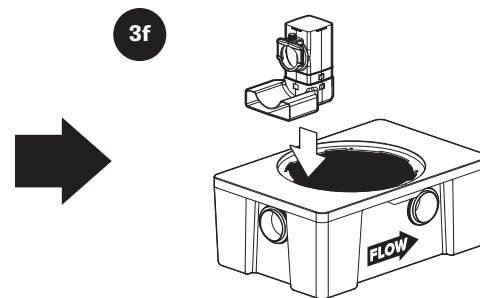

Seat inlet diffuser firmly into saddle adapter.

BURIED INSTALLATION

4 Connect Piping

! Floor Sink Installation

If your dishwashing sink(s) discharges into a floor drain/sink (drain), you must regulate the flow into the drain to avoid an overflow of water onto the kitchen floor. This can be done by installing a valve or flow restriction cap on the sink piping that discharges into the drain.

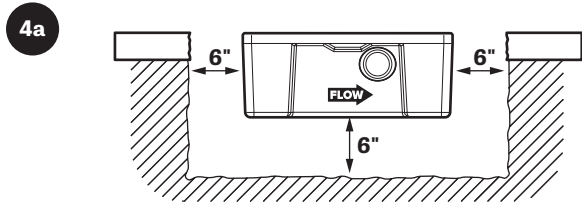
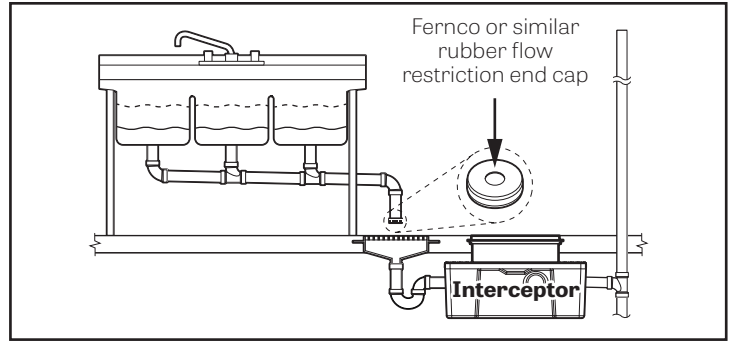

Excavate hole 6" larger than interceptor on all sides.

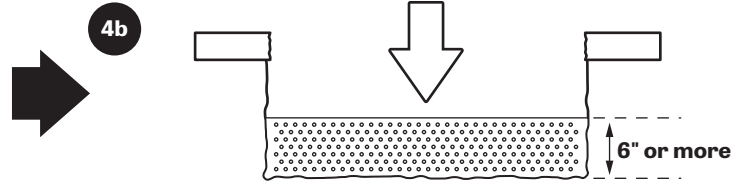

Add crushed aggregate (approximately 3/4" size rock or sand, with no fines) to base of hole.

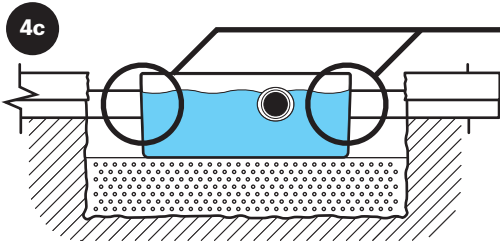

Set interceptor and connect piping using pipe thread sealant or tape approved for use with plastics, fill tank with water so that it remains in place during backfill.

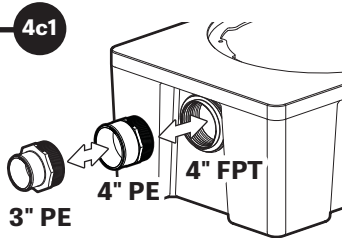

Choose inlet and outlet fittings (included) based on pipe size.

5 Wet or Air Test Piping Per Local Code

1 **! WARNING! DO NOT AIR TEST UNIT OR RISER SYSTEM!**
Doing so may result in property damage, personal injury or death.



Leak? Call customer care at 913-951-3300
8a – 5p M – F CST

6 Backfill and Finished Grade

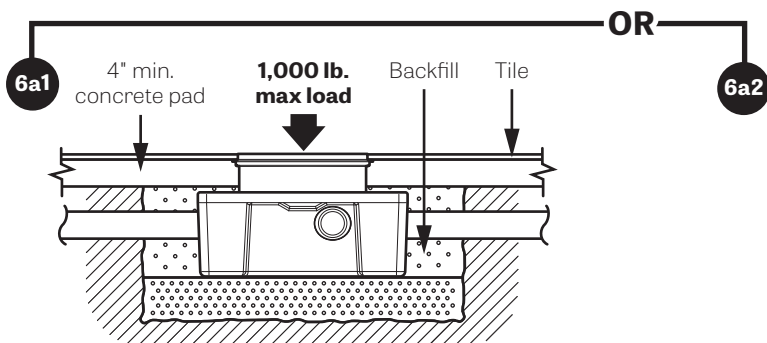

Below Grade with Riser (preferred): See instructions included with FCR1 riser. Backfill evenly around tank using crushed aggregate (approximately 3/4" size rock or sand, with no fines), finish with a minimum 4" thick concrete pad. Vent per local code.

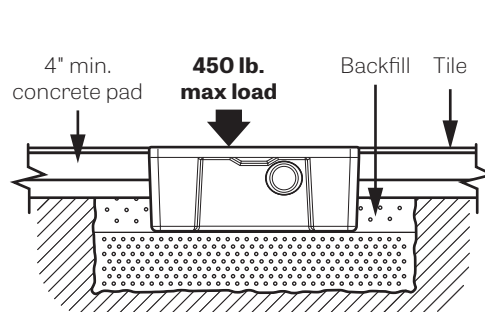

Flush-to-Grade Burials:

! WARNING! Not recommended for heavy foot traffic areas without the use of an internal support system (sold additionally). Contact Customer Care for more details.

1 Open Top Inlet Diffuser Modification

This grease interceptor features a standard closed top inlet diffuser which may be modified to an open top if any of the following conditions apply:

1. This interceptor is part of a series installation and is NOT the first interceptor in the series.
2. An open site drain / indirect connection located upstream is experiencing frequent backups.
3. Local code requires a visual inspection point for the inlet diffuser.

NOTE: Modifying the inlet diffuser to an open-top style eliminates the sewer gas seal and should only be performed if sewer gas is trapped upstream of the unit.

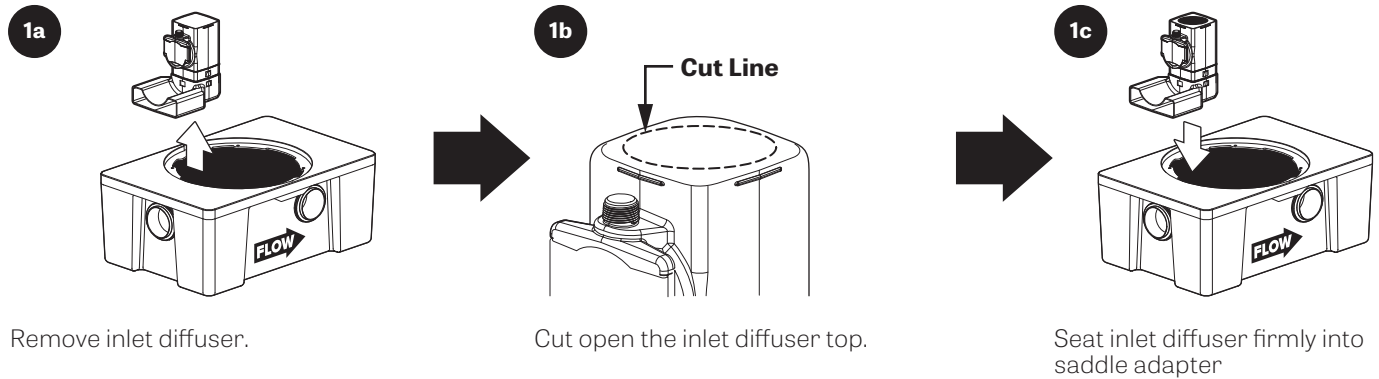

GB3

50/75 GPM
grease interceptor

Specification and Submittal

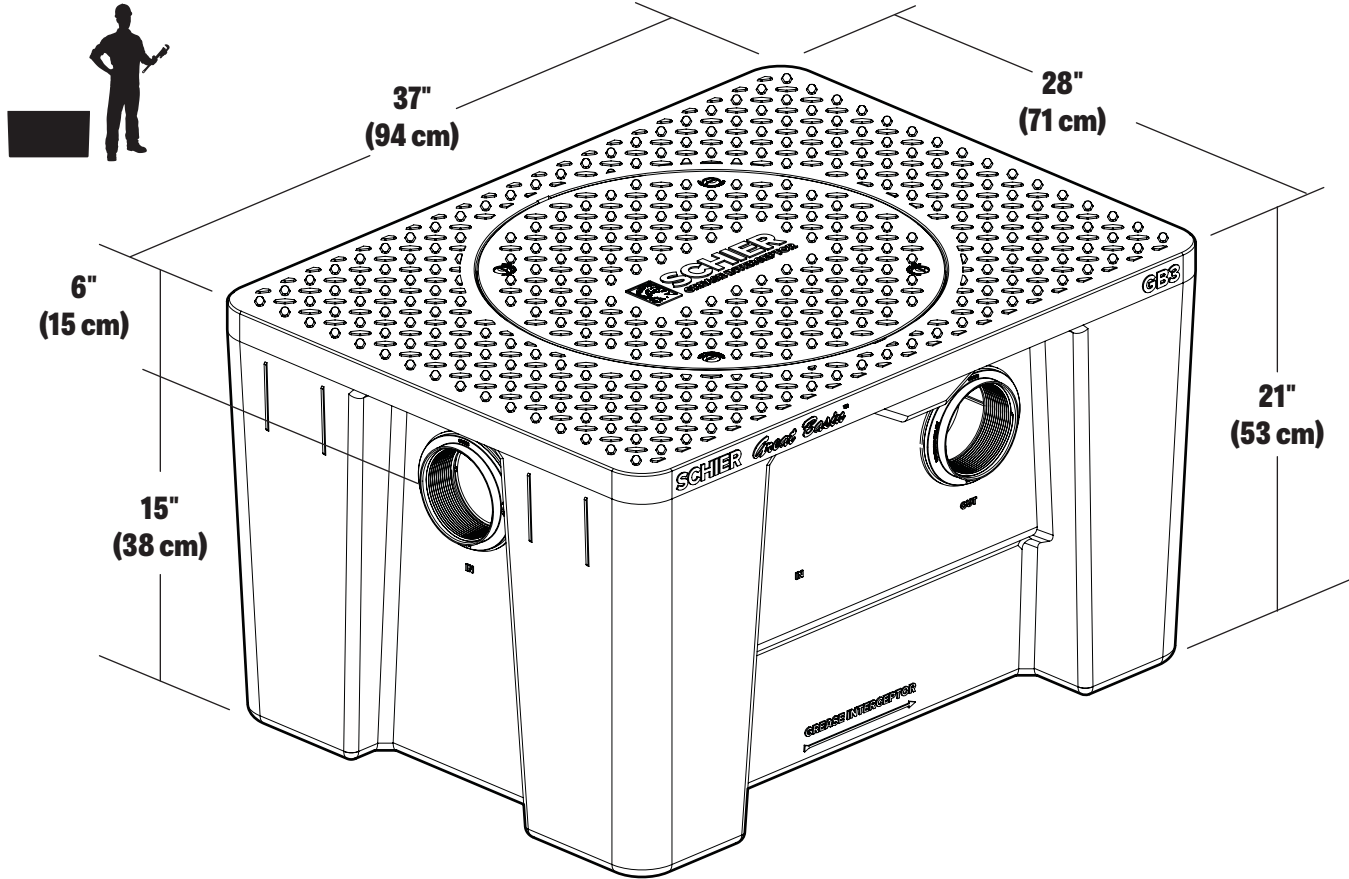

SUBMITTAL

Standard

Location: indoor

Installation: above/below grade

Flow Rates / Grease Capacities:

50 GPM (3.2 L/s) / 272.7 grease lbs. (123.7 kg)

75 GPM (4.7 L/s) / 175.6 grease lbs. (79.7 kg)

Solids Capacity: 1.9 gal. (7.2 L)

Liquid Capacity: 40 gal. (151.4 L)

Weight: 69 lbs. (31.3 kg)

Connections: 3" (75 mm)

and 4" (100 mm) plain end

Cover: bolted gas/water tight polypropylene with 450 lb. load rating, or 1,000 lb. when unit is buried with FCR1 riser

Options

- FO:** fixed outlet diffuser
- FCR1 (x1):** > 2-1/8" - 12" field cut riser
- FCR1 (x2):** > 12" - 25" field cut risers
- CC1:** membrane clamping collar kit (requires FCR1 riser)
- PP1:** pumpout port kit
- F32:** 3" x 2" (75 x 50 mm) FPT fittings (x2)

Approval

Signature:	Date:	Company:
Specifying Engineer:		Engineering Firm:



MODEL NUMBER:
GB3

DESCRIPTION: 50/75 GPM Polyethylene Grease Interceptor

PART #: 4070-001-03

DWG BY: B. Karrer

DATE: 9/11/2018

REV:

ECO:



SPECIAL PRECAUTIONS

For All Schier Grease Interceptor Installations - Failure to follow this guidance voids your warranty

Installation Instructions

Installation instructions and additional components are included with the interceptor. Read all instructions prior to installation. This interceptor is intended to be installed by a licensed plumber in conformance with all local codes.

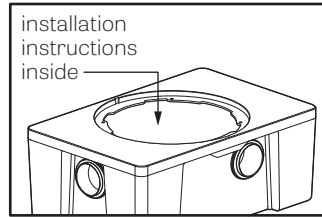

When Installing Interceptor Inside

If your dishwashing sink(s) discharges into a floor drain/sink (drain), you must regulate the flow into the drain to avoid an overflow of water onto the kitchen floor. This can be done by installing a valve or flow restriction cap on the sink piping that discharges into the drain. See drawing above for guidance. For detailed guidance on indirect connections, go to:

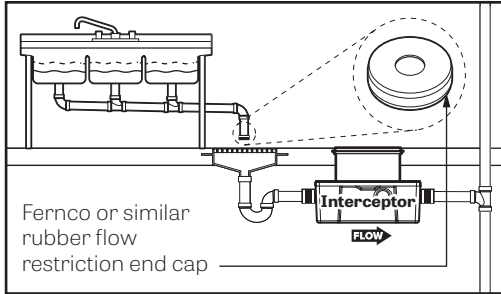

http://webtools.schierproducts.com/Technical_Data/Indirect_Connections.pdf

Flush-to-Grade Burials

Flush-to-Grade buried installations (without a riser) are not recommended for heavy foot traffic areas without the use of an internal support system (sold additionally).

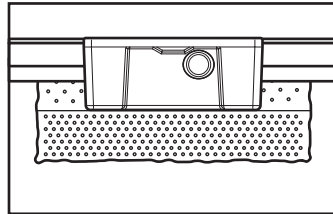

High Temperature Kitchen Water

If water is entering the interceptor at excessive temperature (over 140° F), a drain water tempering valve (DTV) and approved backflow prevention assembly must be installed. Most state and local plumbing codes prohibit water above 140° F being discharged into the sanitary sewer. Water above 140° F will weaken or deform PVC Schedule 40 pipe, poly drainage fixtures like interceptors and erode the coating of cast iron (leading to eventual failure).

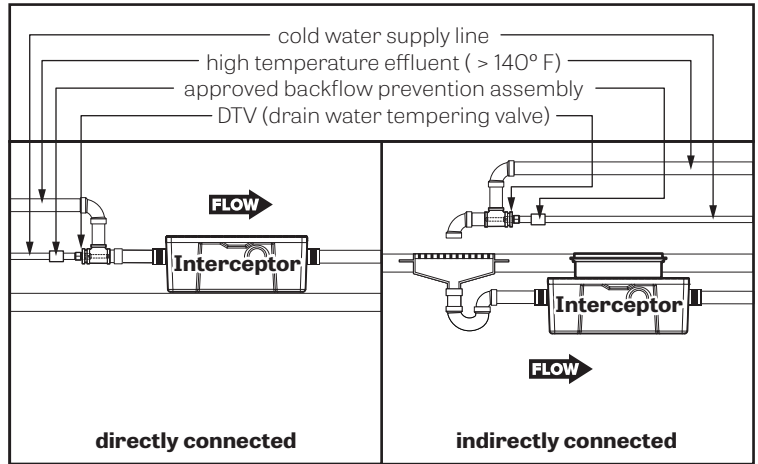

Fully Support Base of Unit

Install unit on solid, level surface in contact with the entire footprint of unit base; for suspended installations design trapeze to support the wet weight of the unit. Do not partially support unit or suspend unit using metal U-channel to create a trapeze

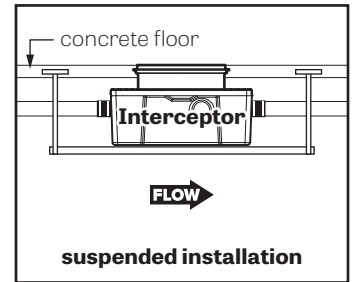

Support Inlet and Outlet Piping

For above grade installations ensure heavy inlet and outlet piping (such as cast iron or long runs) is properly supported or suspended during the entire installation process to prevent connection failure or damage to bulkhead fittings.

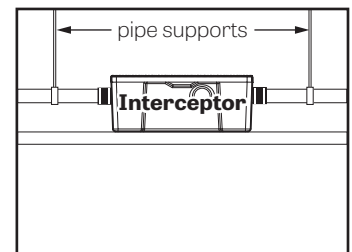

SCHIER
LIFETIME GUARANTEED
GREASE INTERCEPTORS

MODEL NUMBER:
GB3

DESCRIPTION: 50/75 GPM Polyethylene Grease Interceptor

PART #: 4070-001-03

DWG BY: B. Karrer

DATE: 9/11/2018

REV:

ECO:

SPECIFICATION

Notes

- 4" FPT inlet/outlet with 3" and 4" plain end fittings.
- Unit weight - 69 lbs. (wet weight 404 lbs.)
- Capacities - Liquid: 40 gal.
 @50 GPM- Grease: 272 lbs. (37.2 gal.)
 @75 GPM- Grease: 175 lbs. (17.4 gal.)
 Solids: 1.9 gal.
- Built-in flow control.
- For gravity drainage applications only.
- Do not use for pressure applications.
- Cover placement allows full access to tank for proper maintenance.
- Vent not required unless per local code.
- Engineered inlet and outlet diffusers are removable to inspect/clean piping.
- Integral air relief / anti-siphon.

Engineer Specification Guide

Schier Great Basin™ grease interceptor model #GB3 shall be lifetime guaranteed and made in USA of seamless, rotationally-molded polyethylene. Interceptor shall be furnished for above or below grade installation. Interceptor shall be certified to ASME A112.14.3 (type C) and CSA B481.1, with field cut riser system, built-in flow control, built-in test caps and three outlet options. Interceptor flow rate shall be 50 or 75 GPM. Interceptor grease capacity shall be 272 lbs. @ 50 GPM or 175 lbs. @ 75 GPM. Cover shall provide water/gas-tight seal and have minimum 450 lbs. load capacity.

Certified Performance

Great Basin™ hydromechanical grease interceptors are third party performance-tested and listed by IAPMO to ASME #A112.14.3 and CSA B481.1 grease interceptor standards and greatly exceed requirements for grease separation and storage. They are compliant to the Uniform Plumbing Code, the National Standard Plumbing Code, the National Plumbing Code of Canada, and the International Plumbing Code.

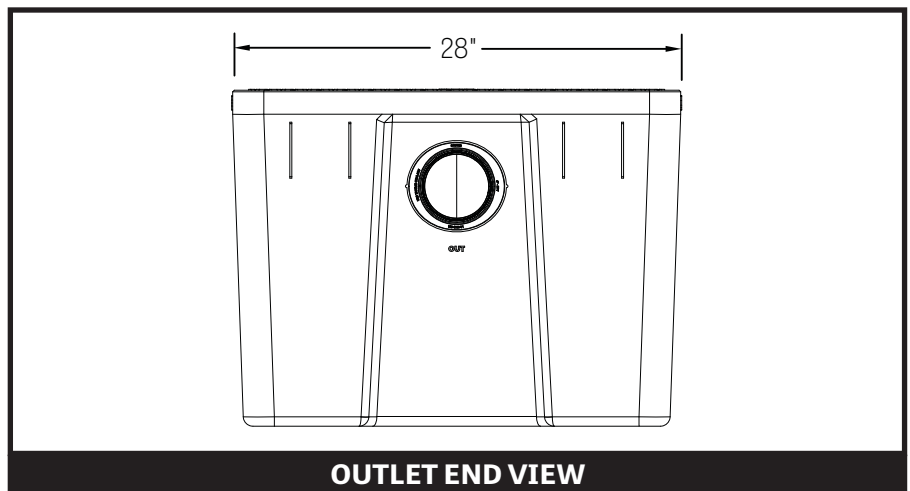
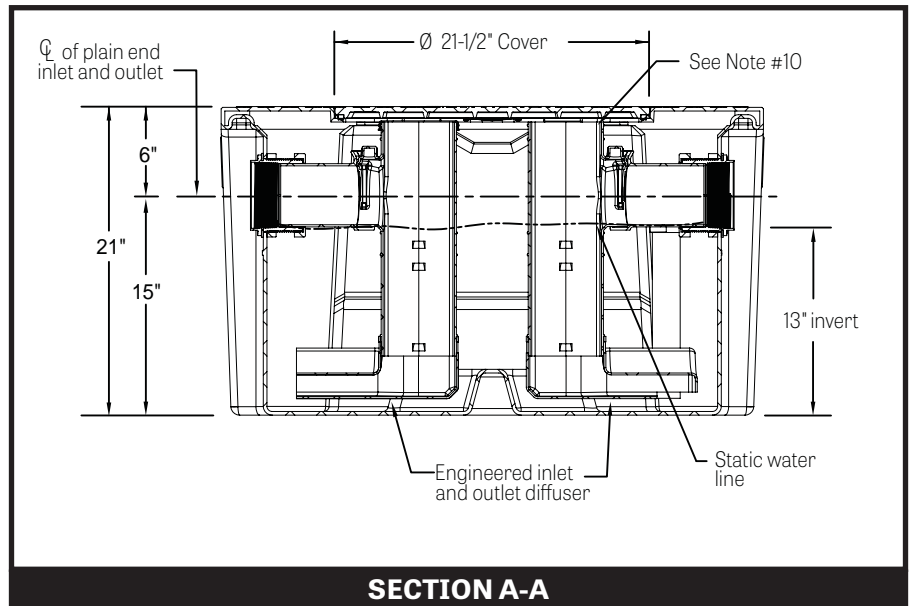
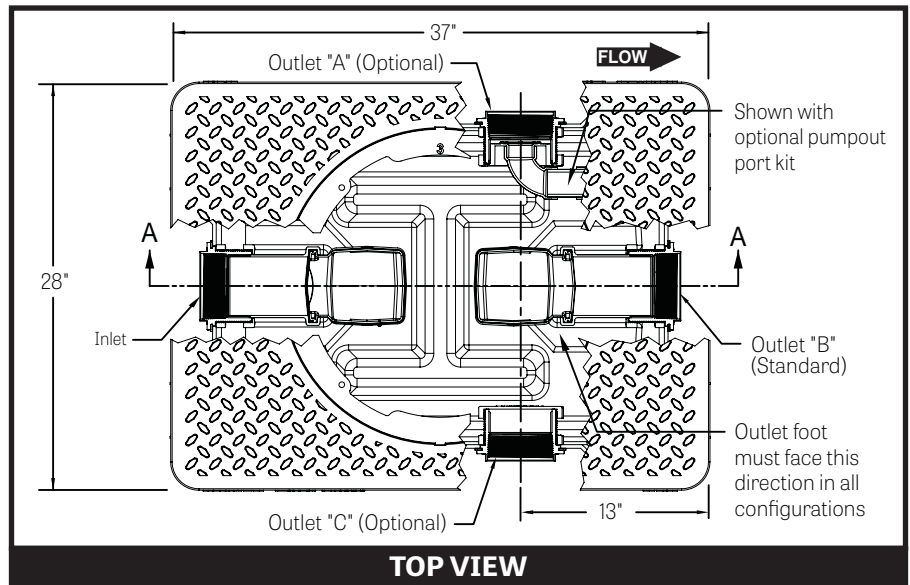

SCHIER
LIFETIME GUARANTEED
GREASE INTERCEPTORS

MODEL NUMBER:
GB3

DESCRIPTION: 50/75 GPM Polyethylene Grease Interceptor

PART #: 4070-001-03

DWG BY: B. Karrer

DATE: 9/11/2018

REV:

ECO: